



Nabtesco

Fact Book 2005

The Nabtesco Group, with our unique motion control technology, will provide safety, comfort and a sense of security in daily lives as well as any form of transportation.



財務ハイライト

CONSOLIDATED FINANCIAL HIGHLIGHTS

(単位：百万円 / ¥ million)	2003/3	2004/3	2005/3
売上高 Net sales	121,525	125,478	137,960
精密機器事業 Precision Equipment Business	21,638	25,439	32,648
輸送用機器事業 Transport Equipment Business	30,214	33,719	35,807
航空・油圧機器事業 Aircraft and Oil Hydraulic Equipment Business	30,729	33,453	34,272
産業用機器事業 Industrial Equipment Business	38,941	32,866	35,232
売上総利益 Gross profit	25,023	28,291	32,733
営業利益 Operating income	6,025	8,345	11,287
経常利益 Ordinary income	5,296	8,477	11,306
当期純利益 Net income	1,892	4,232	5,625
総資産 Total assets	128,738	130,683	133,602
株主資本 Total shareholders' equity	42,410	47,718	52,471
資本金 Capital stock	15,226	10,000	10,000
従業員数(人) Number of employees (person)	3,914	3,851	4,025

- ナブテスコ株式会社(当社)は2003年9月29日に、帝人製機株式会社と株式会社ナブコの純粋持株会社として誕生し、その後2004年10月1日に両社を吸収合併して事業会社いたしました。
- ここに開示する2004年3月期および2005年3月期の財務数値は当社の財務数値です。
- ここに開示する2003年3月期の財務数値は、参考資料として、帝人製機株式会社と株式会社ナブコの財務数値の単純合算値を記載しております。

- Nabtesco Corporation was established on September 29, 2003 as a pure holding company of Teijin Seiki Co., Ltd. and NABCO Ltd. Then, TS Corporation (former Teijin Seiki) and NABCO were merged into Nabtesco on October 1, 2004 and both companies became the operating companies.
- Financial data disclosed here are the data of Nabtesco for the fiscal year ended March 2004 and March 2005.
- Financial data disclosed here for the fiscal year ended March 2003 is a simply sum of the financial data of TS Corporation and NABCO Ltd. and are presented only for your reference.



セグメント情報

SEGMENT INFORMATION

■ 事業別セグメント情報 Net sales by business segment

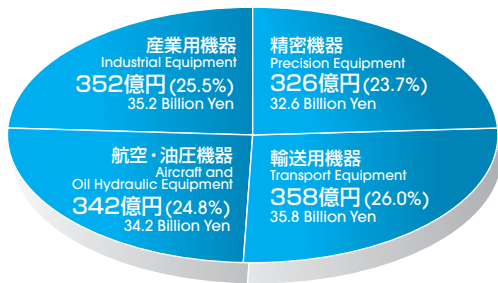

精密機器事業 Precision Equipment Business

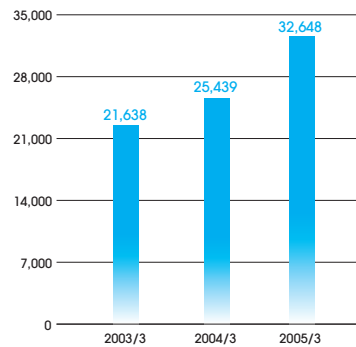

輸送用機器事業 Transport Equipment Business

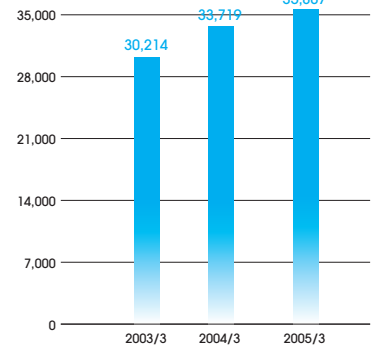

航空・油圧機器事業 Aircraft and Oil Hydraulic Equipment Business

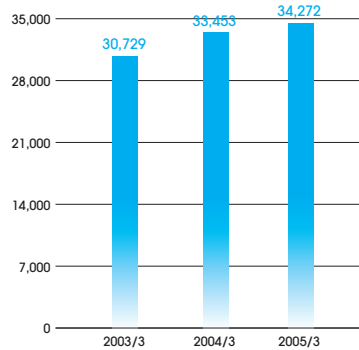

産業用機器事業 Industrial Equipment Business

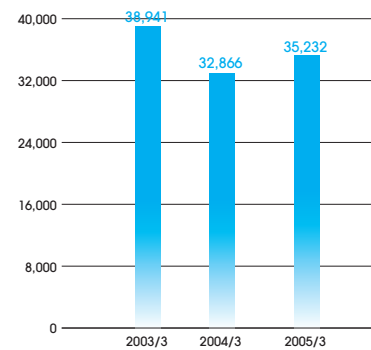

精密機器事業	Precision Equipment Business	2003/3	2004/3	2005/3
売上高	Net Sales	21,638	25,439	32,648
営業利益	Operating income	1,428	3,266	5,099

輸送用機器事業	Transport Equipment Business	2003/3	2004/3	2005/3
売上高	Net Sales	30,214	33,719	35,807
営業利益	Operating income	1,077	1,074	2,177

航空・油圧機器事業	Aircraft and Oil Hydraulic Equipment Business	2003/3	2004/3	2005/3
売上高	Net Sales	30,729	33,453	34,272
営業利益	Operating income	1,484	1,548	783

産業用機器事業	Industrial Equipment Business	2003/3	2004/3	2005/3
売上高	Net Sales	38,941	32,866	35,232
営業利益	Operating income	2,026	2,456	3,227

■ 地域別セグメント情報 Net sales by geographic segment

		アジア Asia	北米 North America	ヨーロッパ Europe	その他の地域 Other region	計 Total
2004/3	海外売上高 Overseas sales	15,488	8,204	7,366	523	31,583
	連結売上高に占める割合 Composition to consolidated net sales	12.4	6.5	5.9	0.4	25.2
2005/3	海外売上高 Overseas sales	14,048	8,609	8,451	152	31,261
	連結売上高に占める割合 Composition to consolidated net sales	10.2	6.3	6.1	0.1	22.7

精密減速機をはじめとした 精密機器が世界の先端産業をサポート

Nabtesco's precision reduction gears and other precision equipment support cutting-edge industries around the world.

小型・軽量・高精度な位置決め性能・高剛性・高効率など、高度な技術に立脚する精密減速機をはじめ、光造形装置に代表される次世代を見据えた事業を展開しています。

当事業の中核を担う精密減速機分野では、産業用ロボット向け、工作機械向け、半導体分野などにその用途領域を着実に拡大しています。このようなあらたな取り組みとともに、既存製品については精度・剛性のアップに対応した新シリーズの開発を進め、さらなる競争力の強化に努めています。特に産業用ロボットの関節用途としては、世界シェアの約6割を有するなど、高い市場評価を得ています。

光造形システムの分野では、業界をリードする開発力、充実したサービス体制を構築しています。自動車関連、電機製造、デジタル家電、精密機器等をはじめとする様々な業界に向けて光造形技術の活用を提案し、積極的な市場開拓を図っています。その他半導体や液晶ガラス基板を搬送、位置決めするための真空アクチュエータ、半導体製造産業で評価の進むドライ真空ポンプ、独自の熱輸送技術による熱制御機器、コイルセンサーで活躍するデジタルロギングシステムなど、世界のユーザーニーズに応える新事業・新製品にも積極的に取り組み、ナブテスコの精密機器事業は、世界の先端産業をサポートしていきます。

Nabtesco's Precision Equipment business has been providing precision reduction gears based on advanced technologies offering compact-size, lightweight, high positioning accuracy, highly rigid and highly efficient features, as well as rapid prototyping machines (stereo lithography) and other equipment and systems focusing on next generation technologies.

For precision reduction gears at the core of the Precision Equipment business, applications are extending to industrial robots, machine tools, and semiconductor manufacturing. Now Nabtesco has just initiated new projects. At the same time, for existing products, Nabtesco has started the development of a new series of products to offer increased accuracy and rigidity, thereby further enhancing competitiveness. In particular, for application to the joints of industrial robots, Nabtesco's precision equipment has been highly rated in the world market and it maintains a dominant share of approximately 60%.

In the business of rapid prototyping systems (stereo lithography), Nabtesco has established an industry-leading development capability and a wide variety of service-providing systems. In fact, Nabtesco has been encouraging various industries, including manufacturers of automobiles, electromechanical systems manufacturing, digital home electronic appliances and precision equipment to utilize this rapid prototyping technology, thereby aiming for positive market development. Nabtesco is also making an aggressive effort to develop new businesses and new products such as vacuum actuators for the transferring and position alignment of wafers or LCD glass substrates, dry vacuum pumps rated highly in the semiconductor manufacturing industry, thermal management products based on proprietary heat transfer technology, and digital logging systems used widely in call centers in order to meet the needs of users around the world, while Nabtesco's precision equipment continues to support cutting-edge industries.

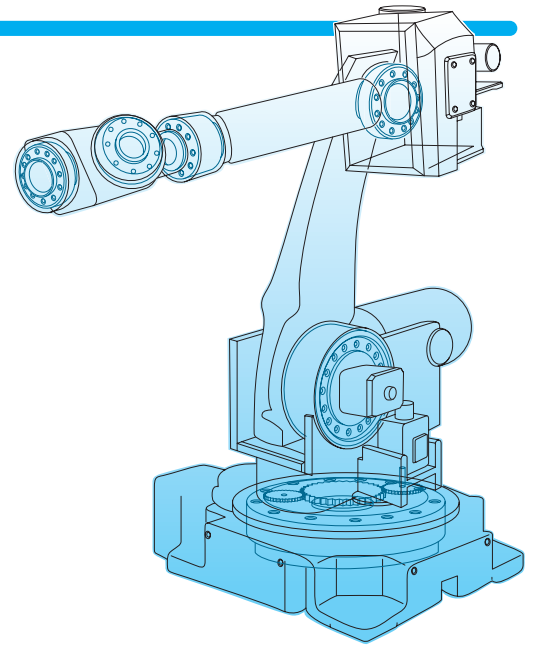

新分野への展開 NEW DEVELOPMENT

■ ドライ真空ポンプ「vigo-vac」の展開

半導体製造プロセスにおいて、ウエハの加工装置内を真空にするためのポンプです。世界初の2段スクロュー式により、従来は困難であった生成物に対する強さと省エネ（電力、冷却水、窒素使用量）の両立を実現。地球温暖化防止対策および製造コスト削減に向けて高まるポンプの省エネ化ニーズを満たしています。

また、第25回（2004年度）優秀省エネルギー機器表彰において「経済産業大臣賞」を受賞しました。



■ Introduction of a dry vacuum pump "vigo-vac"

The dry vacuum pump "vigo-vac" is intended to evacuate the inside of wafer processing unit in the process of semiconductor fabrication. It features the world's first 2-stage screw design that offers both proper resistance to byproducts, which has been unavailable so far, and saving of energy (electric power, cooling water, nitrogen). It meets the increasing need for energy conservation aimed at prevention of global warming and reduction of production costs. It has won the Prize of the Minister of Economy, Trade and Industry for the 25th (fiscal 2004) Superior Energy-Conserving Machinery.

次世代技術を駆使したシステム・製品で、 鉄道車両・自動車・船舶の安全と快適に貢献

Nabtesco's motion control systems and products make full use of advanced technologies to ensure safety and comfort in railway vehicles, automobiles and marine vessels.

鉄道車両用ブレーキ装置やドア装置を主力とする鉄道車両事業、商用車用エアブレーキ装置やエアドライヤを主力とする自動車事業、大型船舶エンジン制御システムを主力とする船用事業を展開しています。

鉄道車両では、新幹線をはじめとして通勤電車・新交通システムに至るまで、また海外では鉄道需要が旺盛な東アジアなどを中心として、鉄道車両用ブレーキ装置・自動扉開閉装置などを提供しています。70年以上におよぶ制御技術をベースに流体を使用しない電気機械式ブレーキシステムをはじめ、メンテナンスフリーの電気式ドア、さらに施設関連の各種省力・省人装置等、鉄道輸送に新しい提案を行っております。

自動車事業では、商用車用ブレーキシステムの国内トップメーカーとして各種ブレーキ製品・油圧クラッチ製品を提供しています。ブレーキ、安全に対する業界の大きな期待に応えるため、常に将来を見つめた活動に取り組み、今日では商用車用エアドライヤおよびブレーキチャンバの国内シェア約90%を確立するに至っています。

船用事業では、日本・シンガポール・オランダの3拠点を中心に全世界をカバーするサービス網を整備し、船用推進機制御装置や電子ガバナシステム等を世界各国に提供しています。中型船から大型タンカーまできめ細かく対応できる技術力・アフターサービス力が高い評価を得ており、2サイクルエンジン用遠隔制御システムについては50%を超える国内トップシェア、世界市場でも約40%のシェアを確立しています。

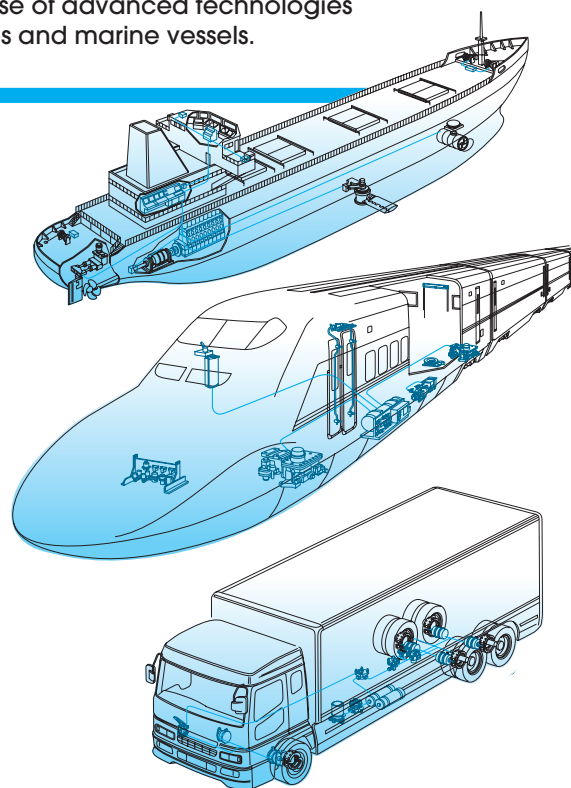

In the Transport Equipment business, Nabtesco has been involved in three major fields. For railway vehicles, Nabtesco primarily deals in railway brake systems and door operating equipment; for automobiles, Nabtesco deals in air brake systems and air dryers for commercial vehicles; and for marine vessels, Nabtesco produces engine control systems for large vessels.

For railway vehicles, Nabtesco provides railway brake systems, door operating system, and other products for high-speed bullet trains (Shinkansen), commuter trains and new forms of transportation systems within Japan as well as to other countries with a focus on East Asia, where demand for railroad construction is high. Based on its experience in control technology over the last 70 years, Nabtesco has been providing advanced solutions for railroad transportation by offering fluid-free electromechanical brake systems, maintenance-free electric automatic sliding doors, and various types of energy- and labor-saving equipment for ancillary facilities.

In the business of automobiles, as the biggest manufacturer of braking systems for commercial vehicles in Japan, Nabtesco provides various brake products and clutch hydraulic products. In order to match the industry's expectations for brakes and to ensure safety, Nabtesco has been taking action through constant consideration for the future. Today, its share of the market for air dryers and brake chambers for commercial vehicles accounts for approximately 90% of the domestic market.

In the marine vessel business, Nabtesco has set up a worldwide network to provide various services, backed up by its three major bases established in Japan, Singapore and the Netherlands through which Nabtesco is supplying marine propulsion control systems, electric digital governor systems and other transport equipment to every country in the world. Nabtesco maintains a reputation for technical competence and after-sales service tailored to vessels ranging from medium-sized craft to very large crude carriers, and has the largest share of the overall market for remote control systems for 2-stroke marine diesel engines with over 50% of the domestic market in Japan and a large share of approximately 40% of the world market.



信頼性の高い技術開発力で 航空機器や建設機械の高度なシステムに対応

Nabtesco's highly rated technological development capability keeps pace with demand in the field of aircraft equipment, construction machinery and other sophisticated systems.

防衛分野ならびに世界を舞台にした民間航空機分野において、信頼性高い高度な製品・システムを展開しています。

防衛分野ではF-86/T-33のライセンス国産に参入後、多くの防衛庁プログラムの油圧機器、エンジン/燃料機器、操縦系統システム、電源システム等の開発から製造・修理までを手掛け、装備品メーカーでは最も経験の深い会社の一つとして、業界での高い評価を得ています。

民間航空機分野では、ボーイング社(米)をはじめセスナ社(米)、ボンバルディア社(加)、エンブラエル社(伯)へ操縦系統システム他、各種装備品等の提供およびアフターサービスを展開しています。特に、B777においては、FBW方式操縦用アクチュエーション・システムを一括受注するなど多くの実績を有しています。長年培ってきた「優れた技術」と「質の高いサービス」により、国内外の航空業界におけるトップクラスのサプライヤーとして、お客様のご要求に応じてきております。

建設工事等で活躍する油圧パワーショベル向けには、その足回りの要となる走行モータを主製品として、市場の高い評価と信頼に基づき常に高いマーケットシェアを維持しています。減速機、油圧モータ、バルブ、ブレーキをコンパクトに一体化した製品は国内外のユーザに広く親しまれています。熟練技術者でなくても高度な作業が行える建機を目指して、エレクトロニクスとハイドロリック技術を融合した、ファインコントロールの研究、開発を積極的に推進しています。

その他、油圧機器技術を応用した新たな取り組みとして、1MWクラス対応の風力発電機用旋回駆動装置の量産を開始するなど、省エネ・環境分野での事業拡大も推進しています。

In the civil aviation sector around the world and in the domestic defense industry, Nabtesco deals in highly reliable, advanced products and systems.

In the defense aircraft market, since its involvement in the domestic production of the F-86/T-33 under a licensing agreement, Nabtesco has been engaged in the development through to the manufacturing and repair of hydraulic equipment, engine accessory/fuel systems, flight control systems and power systems for a number of Japanese Defense Agency programs and has earned a high reputation in the industry as one of the most experienced equipment manufacturers.

In the civil aviation sector, Nabtesco supplies flight control systems and other equipment and also after-sales services to the Boeing Company (US), Cessna Aircraft Company (US), Bombardier Inc. (Canada), and Embraer (Brazil). For the Boeing 777 in particular, Nabtesco has been winning a number of contracts, including a blanket order for FlyByWire (FBW) flight control actuation systems. Through the superior technologies and high-quality services that it has developed and accumulated over many years, Nabtesco has been meeting customer needs as one of the leading suppliers in the aircraft manufacturing industry, both at home and abroad.

For hydraulic excavators that play an essential role in construction work, Nabtesco primarily supplies hydraulic traveling motors, a key component for driving hydraulic excavators, and maintains a large market share backed up by the market's high rating and high level of reliance on its products. The products configured with a reduction gear, a hydraulic motor, valves and a brake integrated in a compact design are very popular among users in Japan and abroad. Nabtesco aggressively promotes research and development on fine control through combined electronics and hydraulics to offer construction equipment that even inexperienced operators can use to perform advanced operations.

In addition, Nabtesco is also expanding its business lines to the fields of energy-efficiency and environment-friendly products as is demonstrated by new business involving the application of hydraulic equipment technology in which Nabtesco has succeeded in mass production of the yaw drives for 1MW class wind turbines.

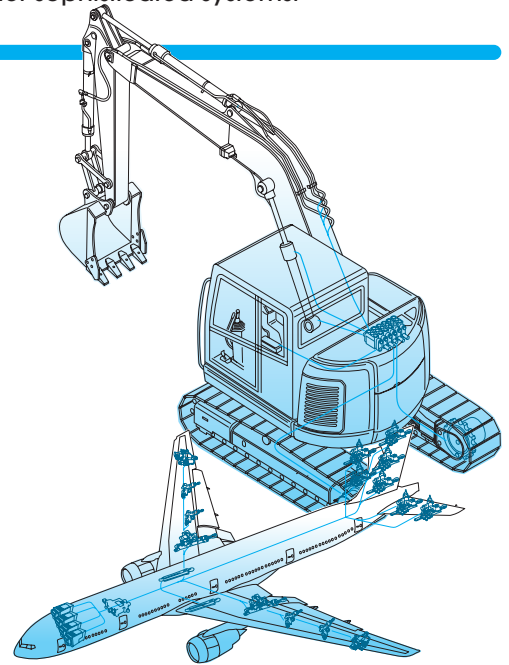

新分野への展開 NEW DEVELOPMENT

■ 優れた耐衝撃性・軽量化を誇る風力発電機用駆動装置の展開

風力発電機用駆動装置は、風向きに応じて風車の方向を回転させる「旋回駆動装置(YAWギア)」と、風力に応じて風車の羽根の角度を調節する「ピッチ駆動装置」から構成されます。高度な油圧機器技術を応用した当社の風力発電機用駆動装置は、その優れた耐久性・軽量性・コンパクトなどの特長を有し、市場から高い評価を得ております。



■ Nabtesco deals in drive units for wind turbines, featuring higher impact resistance and reduced weight.

The drive unit for wind turbines consists of a "yaw drive (yaw gear)" to change the direction of the wind generator to follow the direction of the wind and a "pitch drive" to control the inclination of the blades of the wind generator in response to the velocity of the wind. Nabtesco's drive units for wind turbines have been favorably received in the market for their higher durability, reduced weight, compactness and other features.

あらゆる場所ですべての人に 快適・安全・効率を提供

Nabtesco's industrial equipment offers comfort, safety and efficiency to everyone in every possible location.

自動ドアと自動充填包装機を主力とし、マルチフォーミングマシン、等速ジョイント加工機などの工作機械分野を展開しています。その他、新分野として福祉・医療関連機器でも実績を拡大しています。

日本で一番最初に自動ドアを手掛けたのは当社でありました。現在では建築業界を中心に各種自動ドアや、気密・断熱・放射線遮へいなどの特殊な分野で機能を発揮する産業用ドア、駅に快適性と安全性の向上をもたらすプラットフォームドアシステムなどの商品を提供し、自動ドアの国内シェアでは約45%を誇るに至っています。また主な実績として、建物用自動ドアではロックフェラーセンター、JFK空港、北京新空港などのランドマークで当社製品が採用され、プラットフォームスクリーンドアのトップメーカーとしても国内外に数多くの納入実績を持っています。さらに最近においては時代のニーズに応えるべく、セキュリティ面を強化した自動ドアや携帯型の指紋認証システムなどの商品展開を開始しました。当社の制御技術のさらなる進化を図り、すべての人に快適・安全・効率を提供する自動ドアシステムの提供に努めていきます。

当社は、産業界における自動化・省人化・省力化などのニーズに幅広く対応した機械・機器の開発を進めています。中でも自動充填包装機は、食品分野において非常に高いシェアを有しており、洗剤、化学薬品などにもその用途分野を広げています。技術シーズを常に応用・高度化することで、独創性の高い産業機械・機器の開発を進めていきます。

Nabtesco has been primarily involved in the business of producing machine tools by offering not only automatic doors and automatic pouch fillers/sealers, but also multi-forming machines and CVJ (constant velocity joint) processing machines. In addition, Nabtesco has just entered the new field of welfare and medical equipment and is achieving a high rate of success.

Nabtesco was the first producer of automatic doors in Japan. At present, Nabtesco offers a variety of automatic doors chiefly for the construction industry, industrial doors to ensure insulation against heat, sound and/or radiation, and station platform doors to provide increased safety and convenience. The company has a share of approximately 45% of the domestic automatic door market. In addition, Nabtesco has become widely recognized both at home and abroad as the leading manufacturer of platform screen doors as demonstrated by the successful delivery of automatic doors for buildings at the Rockefeller Center in New York City, JFK International Airport, New Beijing Capital International Airport and other landmarks. Moreover, recently, Nabtesco has started to deal in high security automatic doors and portable fingerprint authentication systems to keep up with the needs of the times. Nabtesco is making every effort to further enhance its control technologies and offer automatic door systems that ensure greater comfort, safety and efficiency for everyone.

Nabtesco is also developing equipment and devices that flexibly and precisely match various industrial needs, such as for automation, labor saving and energy conservation. Among these items of equipment and devices, Nabtesco's automatic pouch fillers/sealers maintain a dominant market share in the food industry and their application is being extended to detergents, chemical agents and other sectors. By constantly planting technological seeds in the soil of practical applications and then refining and nurturing them, Nabtesco continues to develop industrial machinery and equipment that focuses on originality.



新分野への展開 NEW DEVELOPMENT

■ インテリジェント義足

世界初マイクロコンピュータ制御による当社のインテリジェント義足は、空気シリンダ内の弁をマイコン制御することで、ゆっくり歩きから早歩きまですべての歩行スピードに瞬時に対応できるのが特長です。さらに、膝の屈曲角度も160度まで曲げられるので、日常生活のさまざまな姿勢に対応でき、サイクリングやテニスなどのスポーツも楽しめます。



■ Intelligent prosthetic knee joint

Nabtesco's intelligent prosthetic knee joint, the world's first microcomputer-controlled design, features quick response to varying walking speeds from strolling to brisk walking with the aid of the microcomputer control of air cylinder valves. In addition, the knee may be bent to a maximum of 160 degrees. Thus, this intelligent prosthetic knee joint accommodates various body postures in daily activities and even allows users to enjoy sports such as cycling and tennis.

ナブテスコのNo.1

NO.1 PRODUCTS OF Nabtesco

ナブテスコは「モーションコントロール」をキーワードに、当社の強みである「コンポーネント技術」と「システム技術」を活用し、独創性の高い製品開発の推進を図っています。さらにはナブテスコグループというスケールメリットを最大限に発揮し、その強さを一層増しています。

空・陸・海における様々な世界シェアNo.1、国内シェアNo.1の確立など、多方面にわたる強さと将来への可能性を武器に、ナブテスコは進化を遂げていきます。

Nabtesco devotes a lot of its energies to the development of highly innovative products based on the company's strengths in both component technology and systems technology under the keywords "motion control." In addition, Nabtesco is further enhancing its strengths by maximizing the benefits of scale available in the Nabtesco group.

Nabtesco Corporation is advancing continually with its versatile strengths and long-term growth potential by gaining the No. 1 share of both domestic and world markets in various business domains covering air, land and marine applications.

ロボットでも No.1

No. 1 Share of the Robot Market

精密機器 | Precision Equipment Business

小型・軽量・高位置決め精度・高剛性・高効率など、あらゆる市場ニーズを満たした当社製品は産業用ロボットの関節などに世界中で使用され、特にこの分野では世界市場トップとなる約60%のシェアを誇ります。

Nabtesco's precision equipment products are used throughout the world for the joints of industrial robots and other applications due to their compact size, lightweight, highly accurate positioning, high rigidity, high efficiency and other features that meet all the market needs. In the field of joints of industrial robots in particular, Nabtesco boasts the world's largest share of approximately 60%.



新幹線でも No.1

No. 1 Share of the High-Speed Bullet Train (Shinkansen) Market

輸送用機器 | Transport Equipment Business

当社の鉄道車両用機器は、新幹線をはじめ、在来線の電車や新交通システムに至るまで幅広く活躍しています。ブレーキ装置では約50%、ドア開閉装置では約70%の国内市場シェアをそれぞれ誇り、特に新幹線用のドア開閉装置においては約95%と圧倒的な地位を確立するに至っています。

Nabtesco's equipment for railway vehicles is being widely applied in high-speed bullet trains (Shinkansen), as well as in conventional railroad lines and new forms of transportation systems. Nabtesco maintains a dominant share for its transport equipment in the domestic market with approximately 50% for brake systems and approximately 70% for the door opening/closing equipment, and the company boasts the largest share of approximately 95% for the door opening/closing equipment for high-speed bullet trains (Shinkansen).

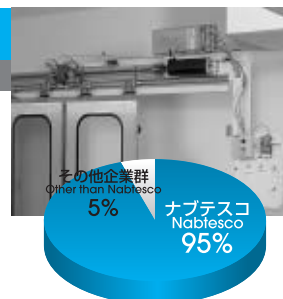

バス・トラックでも No.1

No. 1 Share of the Bus and Truck Market

輸送用機器 | Transport Equipment Business

商用車用エアブレーキのアクチュエーターであるウェッジ・チャンバーで約90%、エアドライヤーで約85%の国内シェアを確立。これまで培ってきた実績、当社製品の安全性・信頼性が市場から高い評価を受けています。

Nabtesco has won an approximately 90% share of the market for wedge chambers, an air brake actuator for commercial vehicles, and also an approximately 85% share for air dryers in the domestic market. The company is highly rated in the market for its long-standing achievements, as well as the safety and reliability of its products.



大型船でも No.1

No. 1 Share of the Large-Scale Ship Market

輸送用機器 | Transport Equipment Business

2サイクルエンジン用遠隔制御システムにおいては国内約55%、世界でも約40%のシェアを確立。日本、シンガポール、オランダの3大拠点を中心とした、きめ細かく対応できる技術力・アフターサービスが高い評価を得ています。

For remote control systems for 2-stroke marine diesel engines, Nabtesco has an approximately 55% domestic market share and an approximately 40% world market share. The company has also won a high reputation in this field for its versatile technical competence and after-sales services backed up by the three key establishments it has founded in Japan, Singapore, and the Netherlands.

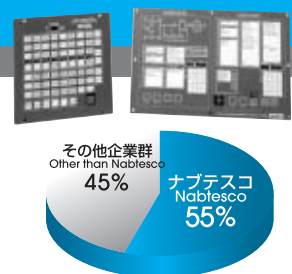



飛行機でも No.1

No. 1 Share of the Aircraft Market

航空・油圧機器 | Aircraft and Oil Hydraulic Equipment Business

航空機の飛行姿勢を制御するフライト・コントロール・アクチュエーターでは世界有数のメーカーとして活躍しています。また国内メーカーとしてはNo.1の納入実績を誇り、フライト・コントロール・アクチュエーション・システム国内市場トップの約50%を確立しています。

For the flight control actuators designed to control the flight attitude of aircraft, Nabtesco has gained recognition as one of the world's leading manufacturers. In addition, in Japan, Nabtesco maintains an approximately 50% share of flight control actuation systems as the country's largest domestic supplier.

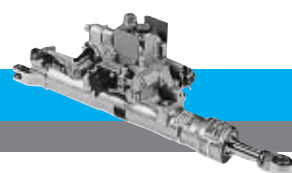

パワーショベルでも No.1

No. 1 Share of the Hydraulic Excavator Market

航空・油圧機器 | Aircraft and Oil Hydraulic Equipment Business

パワーショベル用の走行ユニットでは国内市場トップの約40%を占めています。帝人製機が得意とした中小型と、ナブコが得意とした中大型を併せ、ナブテスコとして小型から大型まで強力な製品ラインアップを確立しています。

For traveling units for hydraulic excavators, Nabtesco boasts the largest share of approximately 40% in the domestic market. By dealing in both small to medium-sized designs covered by Teijin Seiki in conjunction with medium-sized to large designs covered by NABCO, Nabtesco has succeeded in being able to offer design-rich product lineups for any scale.

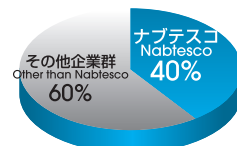

自動ドアでも No.1

No. 1 Share of the Automatic Door Market

産業用機器 | Industrial Equipment Business

建物用自動ドアでは国内で約45%、世界市場でもトップのシェアを有し、国内外の主要なランドマークでも採用されています。

For automatic doors for buildings, Nabtesco has an approximately 45% share of the domestic market and the largest share in the world market, and Nabtesco's automatic doors have been adopted for major landmarks both at home and abroad.

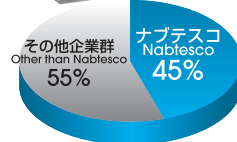

レトルト食品でも No.1

No. 1 Share of the Retort Pouch Food Market

産業用機器 | Industrial Equipment Business

レトルト食品用充填包装機を世界で初めて実現、国内シェア約80%を占めています。また、詰め替え用のシャンプーやリンスといった化成品の分野での用途も広がっています。

Nabtesco is the world's first supplier of automatic filler/sealer for retort pouch foods and has an approximately 80% domestic market share. The application of this equipment is now being extended to shampoo and rinse refills and other functional material products.

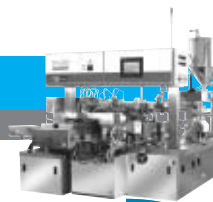

主な経営指標

MAJOR MANAGEMENT INDICES (CONSOLIDATED BASIS)

収益性

PROFITABILITY

■ 売上高総利益率 Gross profit to net sales

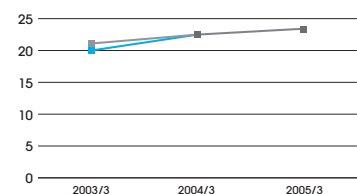

■ 売上高営業利益率 Operating income to net sales

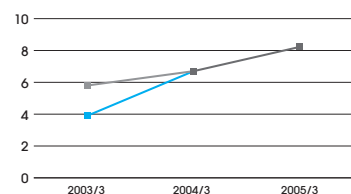

■ 売上高当期純利益率 Net income to net sales

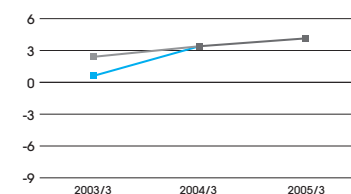

(%)	2003/3	2004/3	2005/3
売上高総利益率 Gross profit to net sales	21.1 20.0	22.5	23.7
売上高営業利益率 Operating income to net sales	5.8 3.9	6.7	8.2
売上高当期純利益率 Net income to net sales	2.4 0.6	3.4	4.1

■ 帝人製機株式会社 Teijin Seiki Co., Ltd. ■ 株式会社ナブコ NABCO Ltd.

安全性

STABILITY

■ 株主資本比率 Shareholders' equity ratio

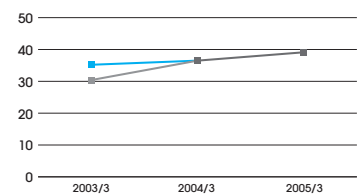

■ 流動比率 Current ratio

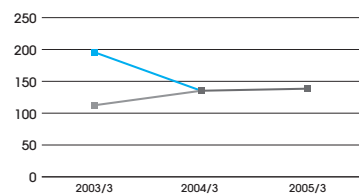

■ インタレスト・カバレッジ(倍) Interest coverage(times)

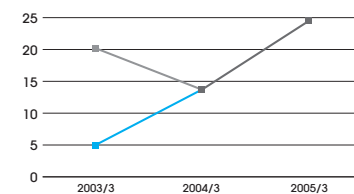

(%)	2003/3	2004/3	2005/3
株主資本比率 Shareholders' equity ratio	30.4 35.2	36.5	39.3
流動比率 Current ratio	112.5 195.4	135.2	138.6
インタレスト・カバレッジ(倍) Interest coverage(times)	20.2 5.0	13.7	24.7

注) インタレスト・カバレッジ = (営業利益 + 受取利息及び配当金) / 支払利息
Note: Interest coverage = (operating income + interest and dividends received) / interest expense.

■ 帝人製機株式会社 Teijin Seiki Co., Ltd. ■ 株式会社ナブコ NABCO Ltd.

効率性

EFFICIENCY

■ 総資産回転率 Total assets turnover

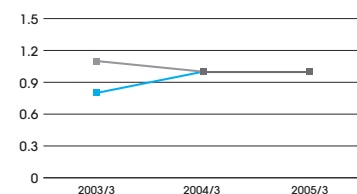

■ 固定資産回転率 Fixed assets turnover

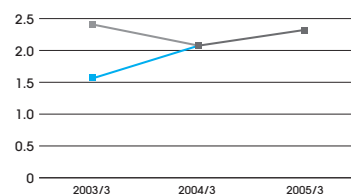

■ 有形固定資産回転率 Tangible fixed assets turnover

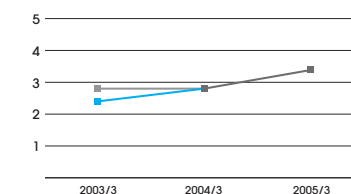

(回/times)	2003/3	2004/3	2005/3
総資産回転率 Total assets turnover	1.1 0.8	1.0	1.0
固定資産回転率 Fixed assets turnover	2.4 1.6	2.1	2.3
有形固定資産回転率 Tangible fixed assets turnover	2.8 2.4	2.8	3.3

注) 総資産・固定資産及び有形固定資産は、期首・期末の平均値で算出。
Note: The amount of total assets, fixed assets and tangible fixed assets are an average of the amount at the beginning of the period and the amount at the end of the period, respectively.

■ 帝人製機株式会社 Teijin Seiki Co., Ltd. ■ 株式会社ナブコ NABCO Ltd.

生産性

PRODUCTIVITY

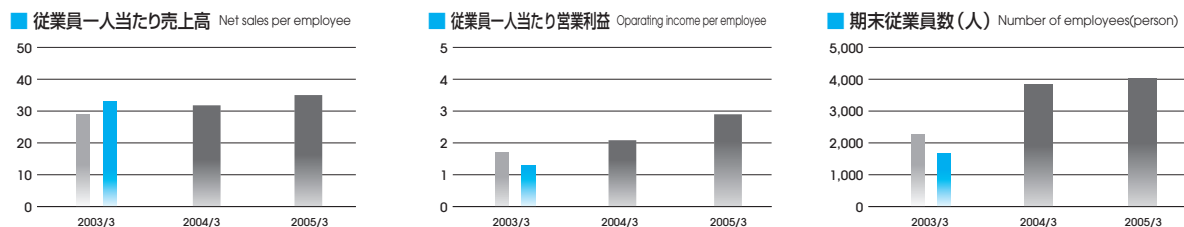

(百万円 ¥ million)	2003/3	2004/3	2005/3
従業員一人当たり売上高 Net sales per employee	28.8 33.0	32.3	35.0
従業員一人当たり営業利益 Operating income per employee	1.7 1.3	2.1	2.9
期末従業員数(人) Number of employees (person)	2,255 1,659	3,851	4,025

注) 従業員一人当たり売上高及び従業員一人当たり営業利益は、期中平均従業員数で算出。
Note: Net sales per employee and operating income per employee are calculated using the average number of employees during the year.

■ 帝人製機株式会社 Teijin Seiki Co., Ltd. ■ 株式会社ナブコ NABCO Ltd.

キャッシュ・フロー

CASH FLOWS

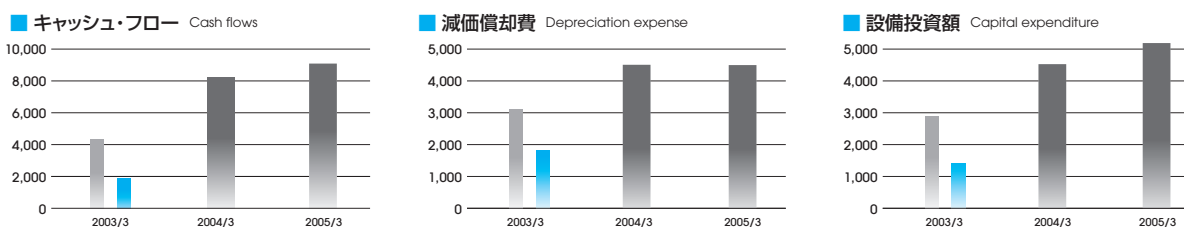

(百万円 ¥ million)	2003/3	2004/3	2005/3
キャッシュ・フロー Cash flows	4,326 1,878	8,255	9,152
減価償却費 Depreciation expense	3,199 1,812	4,508	4,490
設備投資額 Capital expenditure	2,871 1,399	4,528	5,194

注) キャッシュ・フロー=当期純利益+減価償却費-配当金-役員賞与
Note: Cash flows=net income+depreciation expense-dividends-bonuses paid to directors.

■ 帝人製機株式会社 Teijin Seiki Co., Ltd. ■ 株式会社ナブコ NABCO Ltd.

その他指標

OTHERS

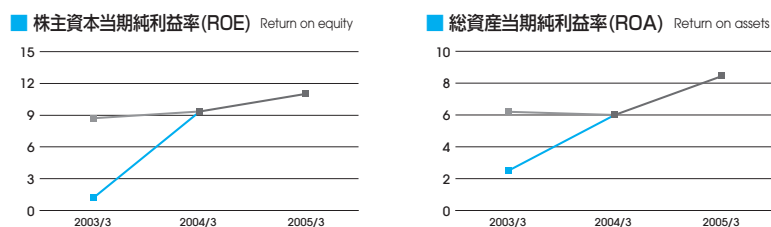

(%)	2003/3	2004/3	2005/3
株主資本当期純利益率(ROE) Return on equity	8.7 1.3	9.4	11.2
総資産当期純利益率(ROA) Return on assets	6.2 2.5	6.0	8.3

注) 総資産及び株主資本は期首・期末の平均値で算出。
ROA=(営業利益+受取利息-配当金-支払利息)/期首・期末の使用総資本の平均値

■ 帝人製機株式会社 Teijin Seiki Co., Ltd. ■ 株式会社ナブコ NABCO Ltd.

Note: Total assets and shareholders' equity are the average of the amount at the beginning of the period and the amount at the end of the period, respectively.
ROA=(Operating income+Interest and dividends received-Interest expenses)/average of total capital employed at the beginning and end of each fiscal year.

連結貸借対照表

CONSOLIDATED BALANCE SHEETS

(百万円/¥ million)

資産の部 Assets	2005/3	2004/3	増減 Increase/Decrease	負債の部 Liabilities	2005/3	2004/3	増減 Increase/Decrease
流動資産 Current assets	75,161	70,888	4,272	流動負債 Current liabilities	54,232	52,441	1,790
現金及び預金 Cash and time deposits	14,353	14,801	(477)	支払手形及び買掛金 Trade notes and accounts payable	27,580	24,133	3,446
受取手形及び売掛金 Trade notes and accounts receivable	43,025	38,580	4,444	短期借入金 Short-term bank loans	8,948	9,212	(264)
たな卸資産 Inventories	14,158	13,226	932	一年内償還予定の社債 Current portion of bonds	—	5,000	(5,000)
繰延税金資産 Deferred income taxes	2,526	2,415	110	一年内返済予定の長期借入金 Current portion of long-term loans	5,662	4,510	1,152
その他 Other current assets	1,482	2,232	(750)	未払法人税等 Income taxes payable	1,433	1,747	(314)
貸倒引当金 Allowance for doubtful receivables	(384)	(367)	(16)	賞与引当金 Accrued employees' bonuses	—	987	(987)
固定資産 Fixed assets	58,440	59,794	(1,353)	土壌改良損失引当金 Reserve for losses on land improvements	1,160	—	1,160
有形固定資産 Property, plant and equipment	41,949	42,895	(946)	その他 Other current liabilities	9,448	6,848	2,599
建物及び構築物 Buildings and structures	15,005	16,385	(1,379)	固定負債 Long-term liabilities	23,526	27,302	(3,775)
機械装置及び運搬具 Machinery and equipment	9,447	8,718	729	長期借入金 Long-term loans	10,428	13,095	(2,666)
工具器具及び備品 Tools, furniture and fixtures	2,284	2,246	37	退職給付引当金 Retirement allowance	12,207	12,802	(595)
土地 Land	14,462	14,881	(419)	役員退職慰労引当金 Reserve for directors' retirement account	211	690	(479)
建設仮勘定 Construction in progress	748	663	84	その他 Other long-term liabilities	680	713	(33)
無形固定資産 Intangible assets	1,791	1,983	(191)	負債合計 Total liabilities	77,759	79,744	(1,984)
投資その他の資産 Investments and other assets	14,699	14,915	(215)				
投資有価証券 Investments in securities	11,361	9,333	2,027	少数株主持分 Minority interests			
繰延税金資産 Deferred income taxes	1,082	2,492	(1,409)	少数株主持分 Minority interests	3,371	3,220	150
その他 Other investments and other assets	2,509	3,394	(884)				
貸倒引当金 Allowance for doubtful receivables	(254)	(304)	51	資本の部 Shareholders' equity			
				資本金 Capital stock	10,000	10,000	—
				資本剰余金 Capital surplus	17,709	17,709	(0)
				利益剰余金 Earned surplus	23,172	18,677	4,494
				その他有価証券評価差額金 Net unrealized gains on securities	2,880	2,473	407
				為替換算調整勘定 Translation adjustments	(1,128)	(1,060)	(68)
				自己株式 Treasury stock, at cost	(162)	(81)	(81)
				資本合計 Total shareholders' equity	52,471	47,718	4,753
資産合計 Total assets	133,602	130,683	2,918	負債、少数株主持分及び資本合計 Total liabilities, minority interests and shareholders' equity	133,602	130,683	2,918

連結損益計算書

CONSOLIDATED STATEMENTS OF INCOME

(百万円/¥ million)

		2005/3	2004/3	増減 Increase/Decrease
売上高	Net sales	137,960	125,478	12,481
売上原価	Cost of sales	105,227	97,187	8,040
売上総利益	Gross profit	32,733	28,291	4,441
販売費及び一般管理費	Selling, general and administrative expenses	21,446	19,946	1,499
営業利益	Operating income	11,287	8,345	2,941
営業外収益	Non-operating income	849	1,693	(844)
受取利息	Interest income	22	42	(19)
受取配当金	Dividend income	76	38	37
持分法による投資利益	Equity in earnings of an affiliate	230	838	(608)
賃貸料収益	Rents income	324	418	(94)
その他	Other	195	354	(159)
営業外費用	Non-operating expenses	829	1,561	(732)
支払利息	Interest expense	461	616	(154)
為替差損	Foreign exchange loss	—	277	(277)
たな卸資産処分損	Loss on disposal of inventories	88	183	(95)
その他	Other	279	482	(203)
経常利益	Ordinary income	11,306	8,477	2,829
特別利益	Extraordinary gains	864	180	683
固定資産売却益	Gain on sales of fixed assets	385	16	368
投資有価証券売却益	Gain on sales of investment securities	0	121	(120)
貸倒引当金戻入益	Reversal of allowance for doubtful accounts	57	43	14
事業撤退補填金	Compensation for loss on withdrawal from business	420	—	420
その他	Other	0	—	0
特別損失	Extraordinary losses	2,945	2,058	887
固定資産処分損	Loss on disposal of fixed assets	1,381	709	671
投資有価証券評価損	Write-down of investment securities	13	61	(48)
ゴルフ会員権評価損	Write-down of golf membership rights	13	100	(86)
賃借物件解約損	Loss on cancellation of leasehold property	335	—	335
退職給付費用	Special contribution to a pension fund	—	1,183	(1,183)
土壌改良損失引当損	Loss on reserve for losses on land improvements	1,160	—	1,160
その他	Other	41	3	38
税引前当期純利益	Net income before income taxes	9,225	6,599	2,625
法人税、住民税及び事業税	Corporate, resident and business taxes	2,274	2,239	34
法人税等調整額	Adjustment for corporate and other taxes	1,063	(147)	1,210
少数株主利益	Minority interest income	262	275	(13)
当期純利益	Net income	5,625	4,232	1,393

連結キャッシュ・フロー計算書

CONSOLIDATED STATEMENTS OF CASH FLOWS

(百万円/¥ million)

		2005/3	2004/3	増減 Increase/Decrease
I 営業活動によるキャッシュ・フロー	Operating activities:			
税金等調整前当期純利益	Net income before income taxes and adjustments	9,225	6,599	2,625
減価償却費	Depreciation and amortization	4,490	4,508	(18)
連結調整勘定償却額	Amortization of cost in excess of net book values of consolidated subsidiaries	55	57	(2)
貸倒引当金の増減額	Increase (Decrease) in allowance for doubtful receivables	(60)	13	(74)
退職給付引当金の増減額	Increase (Decrease) in retirement benefits of employees	(593)	1,597	(2,190)
役員退職慰労引当金の減少額	Provision for (reversal of) directors' retirement allowances	(482)	(158)	(324)
受取利息及び受取配当金	Interest and dividend income	(98)	(80)	(18)
支払利息	Interest expense	461	616	(154)
為替差損	Foreign exchange loss	0	6	(6)
持分法による投資利益	Equity in earnings of an affiliates	(230)	(838)	608
固定資産売却益	Gain on sales of fixed assets	(385)	(16)	(368)
固定資産処分損	Loss on disposal of fixed assets	1,381	709	671
投資有価証券売却益	Gain on sales of investment marketable securities	(0)	(121)	120
投資有価証券評価損	Losses from valuation of investment securities	13	61	(48)
ゴルフ会員権評価損	Write-down of golf membership rights	13	100	(86)
賃借物件解約損	Loss on cancellation of leasehold property	335	—	335
事業撤退補填金	Compensation for losses on withdrawal from business	(420)	—	(420)
土壌改良損失引当損	Reserve for losses on land improvements	1,160	—	1,160
売上債権の増減額	Decrease (Increase) in notes and accounts receivable	(4,820)	2,941	(7,762)
たな卸資産の増減額	Decrease (Increase) in inventories	(772)	863	(1,635)
その他資産の減少額	Decrease in other assets	250	1,274	(1,024)
仕入債務の増減額	Increase (Decrease) in notes and accounts payable	3,811	(316)	4,128
未払消費税等の増減額	Increase (Decrease) in consumption taxes payable	144	(63)	208
その他負債の増減額	Increase (Decrease) in other liabilities	281	(343)	625
役員賞与の支払額	Bonuses to directors	(80)	(54)	(26)
小計	Subtotal	13,679	17,358	(3,678)
利息及び配当金の受取額	Interest and dividends received	305	126	178
利息の支払額	Interest paid	(513)	(629)	116
法人税等の支払額	Income taxes paid	(2,369)	(1,105)	(1,264)
営業活動によるキャッシュ・フロー	Net cash and cash equivalents provided by operating activities	11,102	15,750	(4,648)
II 投資活動によるキャッシュ・フロー	Investing activities:			
定期預金の預入による支出	Decrease in time deposit	(12)	(45)	32
定期預金の払戻による収入	Increase in time deposit	18	23	(5)
有形固定資産の取得による支出	Purchases of property, plant and equipment	(4,494)	(4,381)	(112)
有形固定資産の売却による収入	Proceeds from sale of property, plant and equipment	1,551	729	821
無形固定資産の取得による支出	Purchases of intangible assets	(179)	—	(179)
有価証券の売却による収入	Proceeds from sale of investments securities	40	—	40
投資有価証券の取得による支出	Purchases of investments in securities	(1,578)	(703)	(874)
投資有価証券の売却による収入	Proceeds from sale of investments securities	21	640	(619)
貸付金の実行による支出	Payment of short-term loans	(12)	(15)	2
貸付金の回収による収入	Proceeds from repayment of short-term loans	6	15	(8)
その他投資活動による収入	Income from other investing activities	477	—	477
その他投資活動による支出	Expenses from other investing activities	(408)	(68)	(339)
投資活動によるキャッシュ・フロー	Net cash and cash equivalents used in investing activities	(4,569)	(3,804)	(764)
III 財務活動によるキャッシュ・フロー	Financing activities:			
短期借入金の純減少額	Decrease in short-term bank loans	(251)	(1,496)	1,244
長期借入金の借入れによる収入	Proceeds from long-term loans	3,000	191	2,808
長期借入金の返済による支出	Repayment of long-term loans	(4,506)	(3,350)	(1,155)
社債の償還による支出	Repayment of debentures	(5,000)	—	(5,000)
株式移転前完全子会社の株式発行による収入	Proceeds from issuance of common stock	—	144	(144)
自己株式の取得による支出	Payments for purchases of treasury stock	(82)	(110)	28
自己株式の売却による収入	Proceeds from sales of treasury stock	4	98	(94)
株式移転交付金の支払額	Stock transfer payments	—	(317)	317
配当金の支払額	Cash dividends paid	(889)	(435)	(453)
少数株主への配当金の支払額	Cash dividends paid of subsidiaries for minority	(84)	(60)	(23)
財務活動によるキャッシュ・フロー	Net cash and cash equivalents provided by financing activities	(7,808)	(5,335)	(2,473)
IV 現金及び現金同等物に係る換算差額	Effect of exchange rate changes on cash and cash equivalents	19	(64)	83
V 現金及び現金同等物の増減額	Increase or Decrease in cash and cash equivalents	(1,256)	6,546	(7,803)
VI 現金及び現金同等物の期首残高	Cash and cash equivalents at beginning of year	14,476	7,929	6,546
VII 新規連結による現金及び現金同等物の増加額	Increase in cash and cash equivalents from newly consolidated company	815	—	815
VIII 現金及び現金同等物の期末残高	Cash and cash equivalents at end of year	14,035	14,476	(441)

会社概要

CORPORATE INFORMATION

会社名 ナブテスコ株式会社
設立 2003年9月29日
所在地 東京都港区海岸1丁目9番18号
資本金 100億円
従業員数 単体 2,025人 (2005年3月31日現在)
 連結 4,025人
連結子会社 国内 18社 (他持分法適用会社 7社)
 海外 14社 (他持分法適用会社 2社)
役員構成
 取締役会長 興津 誠
 代表取締役社長 松本 和幸
 代表取締役 秋山 晋一
 専務取締役 田中 均
 専務取締役 吉田興四郎
 常務取締役 岡本 正巳
 取締役 阿部 裕
 取締役 佐和 博
 取締役 坪内 繁樹
 社外取締役 高田 治
 監査役 萩原 茂明
 監査役 松田 孝介
 社外監査役 船井 孝祐
 社外監査役 石丸 哲也
 社外監査役 柴山 高一

Company Name Nabtesco Corporation
Established September 29, 2003
Location 9-18, Kaigan 1-chome, Minato-ku, Tokyo
Capital 10 billion yen
Number of Employees Non-consolidated basis: 2,025 persons (As of March 31, 2005)
 Consolidated Basis: 4,025 persons
Consolidated Subsidiaries Domestic : 18 companies
 (Other equity method applications companies: 7)
 Overseas : 14 companies
 (Other equity method applications companies: 2)
Board Members
 Chairman Makoto Okitsu
 President & CEO Kazuyuki Matsumoto
 Senior Managing Directors, Directors of the Board Shinichi Akiyama
 Hitoshi Tanaka
 Managing Directors, Directors of the Board Koshiro Yoshida
 Masami Okamoto
 Directors of the Board Hiroshi Abe
 Hiroshi Sawa
 Shigeki Tsubouchi
 Osamu Takata
 Statutory Auditors Shigeaki Hagihara
 Kosuke Matsuda
 External Statutory Auditors Kosuke Funai
 Tetsuya Ishimaru
 Koichi Shibayama

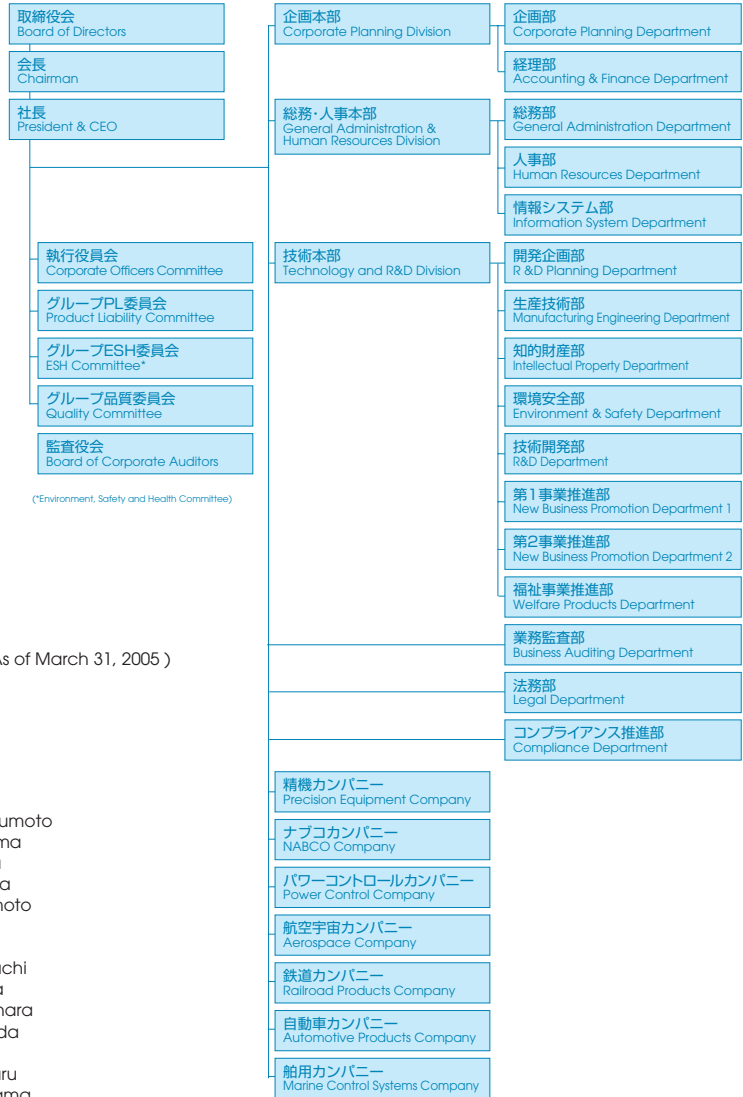

Nabtesco Corporation

9-18, Kaigan 1-chome, Minato-ku, Tokyo 105-0022, Japan
Tel.+81-3-3578-7070
Fax.+81-3-3578-7237

www.nabtesco.com