



# Fact Book 2002

Year ended March 31, 2002

2002年3月期

# Message from the President

ごあいさつ

代表取締役社長  
興津 誠



President & CEO  
Makoto Okitsu

当社は、1944年に帝国人造絹絲株式会社（現、帝人株式会社）より分離独立し、帝人航空工業株式会社としてスタートしました。（45年に現在の社名である帝人製機株式会社と社名変更）

当社は、設立以来、時代の要請を先取りした独創性の高い技術を開発し、産業界の多様なニーズにお応えしてきました。繊維機械の開発・製造からスタートし、徐々に技術の幅と奥行きを増し、事業領域の拡大を果たしてきました。55年には航空機器の製造を、59年には産業機械の製造を、そして61年には油圧機器の製造を開始しました。また、メカトロニクス技術の高度化に対応して、産業用ロボットの分野を対象とした精密減速機の開発にも着手し、85年に製造を開始しました。

さらに、国内外における事業の積極化を目指して、特異性の高い技術を基礎とした新会社の設立、独自技術を有する企業への出資・系列化等を推進し、帝人製機グループの強化を進めてきました。現在、当社の関係会社は、国内子会社12社、海外子会社8社、国内関連会社2社(持分法適用)の合計22社となっています。

グローバルに活躍する中堅の高収益企業グループを目指して、帝人製機グループは、現在、「精密機器・新事業」「航空・油圧機器事業」「繊維・産業機械事業」の3つの事業セグメントで事業を展開しています。これにより、当グループは、今後もグローバルなお客様のニーズに俊敏に対応し、21世紀の新しい産業界をリードしていきます。

帝人製機グループは、また、環境保全と従業員の安全・健康の確保を目指し、2000年4月にグループ共通の「環境理念」を新たに制定し、「ESH活動」（環境・安全・健康管理活動）を展開しています。さらに、2001年6月に帝人製機（株）及び大亜真空（株）で国際規格ISO14001の認証を取得し、今後、帝人製機グループ各社への認証取得の拡大を図ります。

Teijin Seiki Co., Ltd. was originally established for the manufacture of aircraft equipment under the name of Teijin Koku Kogyo Co., Ltd., in 1944, as a spin-off from Teikoku Rayon Co., Ltd. (presently TEIJIN Limited). The Company assumed its current name in 1945.

Since our establishment, we have continued to respond to the various needs of industry by developing highly innovative technology that anticipates the demands of the times. Beginning our operations with the development and manufacture of textile machinery, we have steadily increased the depth and breadth of our technology, thereby expanding our business scope. In 1955, we started manufacturing aircraft equipment. In 1959, we added an industrial machinery business. And in 1961, we began manufacturing oil hydraulic equipment. In response to the growing sophistication of mechatronics technology, we commenced developing precision reduction gears for industrial robots and manufacturing them in 1985.

Moreover, with the aim of developing our business in Japan and overseas, we are strengthening the Teijin Seiki Group by establishing our affiliated companies with highly specialized technologies and by investing in companies with original technologies. In addition to the parent company, the Group currently comprises 22 companies: 12 domestic subsidiaries, 8 overseas subsidiaries, and 2 domestic affiliates (over which Teijin Seiki has the ability to exercise significant influence).

Aiming to become a leading and highly profitable group operating vigorously globally, the Teijin Seiki Group is now developing three business segments: "Precision Equipment and New Business", "Aircraft and Oil Hydraulic Equipment" and "Textile and Industrial Machinery". The Group will be a leader in the new industries of the 21st century by quickly responding to global customer needs in these three segments.

In April 2000, the Teijin Seiki Group established a new group-wide Environmental Charter, aiming to protect the environment and ensure the safety and health of its employees. Based on that charter, the Group began Environment, Safety, and Health control activities (ESH actions). In June 2001, Teijin Seiki Co., Ltd. and Diavac Limited, a Group member, led the way in obtaining ISO 14001 certification, and they will be followed by all other Group members in due course.

## 企業理念 Corporate Philosophy

独創的な技術で世界に貢献し、人と自然を大切にし、社会から信頼される企業を目指してたゆまぬ前進をする。

We will make unceasing efforts to win the trust of the public,  
by contributing to world progress through our technology and by respecting people and nature.

## 経営基本方針 Fundamental Management Policies

- ・ 利益ある成長の追求
- ・ グループ経営の強化
- ・ 技術開発、技術革新の推進
- ・ グローバル化の推進
- ・ Pursuit of Profitable growth
- ・ Enhancement of Group-oriented management
- ・ Propelling Technological progress and Innovation
- ・ Propelling and Strengthening Globalization

### "Change for 21"

「グローバルに活躍する中堅の高収益企業グループ」を目指して

Aiming to be a leading and highly profitable corporate group that can compete globally

#### ● 中期経営計画の概要 Outline of the Medium-term Management Plan

##### (1) グループ経営の強化

連結の範囲を全子会社・関連会社に拡大し、明瞭な連結決算を行います。

連結対象範囲：社内カンパニー2社、子会社等22社  
社内カンパニー及び子会社に対して事業展開上の責任権限を委譲し、経営のスピードアップを図ります。(但し、資源投入は本社が統制)  
グループ全体で情報の共有化を進めます。

##### (2) 成長のためのポートフォリオ変革

事業ポートフォリオを高成長分野にシフトします。アライアンス、M & Aなどによる事業拡大も積極的に追求します。

##### (3) グローバルスタンダードの適用

株主を重視し、企業価値を高めるため、ROE、キャッシュフローを共通の重要管理目標として、財務体質の強化を図ります。

グループとしてISO14001の統合認証の取得等により、地球環境を重視し、人間にやさしい経営を行います。

##### (4) コーポレートガバナンスの拡充

透明かつ公正な経営と迅速な意思決定が求められる中、取締役の削減、執行役員制度の導入など、経営改革を推進しています。

法令、社会倫理、社会規範を尊重、遵守すると共に、グループ監査役会の実施により監査体制を強化します。

##### (1) Strengthen Group management

- Expand the scope of consolidation to all subsidiaries and affiliates and prepare reports on a clearly understandable consolidated basis.  
Scope of consolidation: 2 internal companies, 22 subsidiaries and affiliates.
- Accelerate management decision making by giving internal and subsidiaries responsibility for developing their businesses (However, the parent company will control allocation of resources.).
- Increase information exchange within the Group.

##### (2) Restructure business portfolio with an emphasis on growth

- Shift the business portfolio to high-growth fields.
- Actively pursue business expansion through alliances and mergers and acquisitions.

##### (3) Implement global standards

- In consideration of the interests of shareholders, we will strengthen our financial structure by adopting ROE and cash flow as principal management indices and strive to increase shareholder value.
- We will achieve ISO 14001 certification for the overall Group and operate an environment- and people-friendly business.

##### (4) Enhance corporate governance

- Because of the need for transparent and fair business practices and prompt decision making in today's markets, we have reduced the number of directors on our board, introduced a corporate officer system, and taken other measures to improve our management.
- We pledge to observe all laws and regulations and give due consideration to social conventions and rules. At the same time, we will strengthen our compliance monitoring system by establishing a Group meeting for compliance officers.

#### ● 中期目標(連結) Medium-term Targets (Consolidated)

売上高 (Net Sales)	売上高当期利益率 (Net Income to Net Sales)	ROE (Return on Equity)	フリーキャッシュフロー (Free Cash Flow)
2002年度：800億円 (FY2002：¥80 Billion)	2002年度：5%以上 (FY2002：Over 5%)	2002年度：15%以上 (FY2002：Over 15%)	各年度黒字とし、2000年度～2002年度累計150億円以上を目標。 Positive free cash flow every year, and accumulated free cash flow of more than ¥15.0 billion for FY2000 through FY2002.
2005年度：1,500億円 (FY2005：¥150 Billion)			

# Business Outline by Segment

## セグメント別事業内容

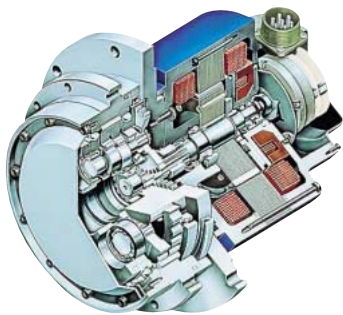

Vigo Servo



Rapid Meister 6000

1971年～ 真空ポンプ・真空装置  
Vacuum Pump and Equipment

1985年～ 精密減速機・サーボ・アクチュエータ  
Precision Reduction Gear / Servo Actuator

1994年～ 三次元光造形装置  
Rapid Prototyping System

1999年～ 半導体装置用アクチュエータ  
Actuator for Semiconductor

熱制御デバイス  
Heat Lane

ロギングシステム  
Logging System

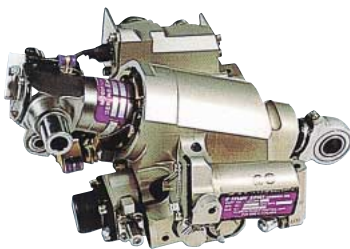

B777 AILERON  
POWER CONTROL UNIT

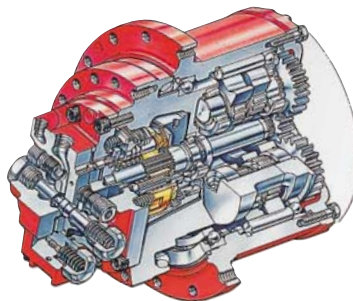

Cross-section of a reduction drive

1944年(設立)～ 航空機用機器  
Aircraft Equipment

1976年～ 減速機付油圧モータ  
Hydraulic Motor with Reduction Gear

2002年～ 風力発電機用駆動装置  
Actuation Unit for Wind Turbine



AWH-SERIES  
High Speed Automatic Take-up  
Winder



TT-9CWS  
High Speed Pouch Filler / Sealer  
Machine

1945年～ 化纤織用設備  
Textile Machinery

1959年～ 鍛圧機械・工作機械  
Forming Machine / Machine Tool

1966年～ 自動計量包装機械  
Automatic Packaging Equipment

1975年～ 自動車用部品・金型・治具  
Automotive Parts

## 精密機器・新事業

### Precision Equipment and New Business

#### 精密機器分野

精密減速機及びサーボモータと精密減速機を一体化した精密サーボアクチュエータが主力製品です。当社の製品は、小型・軽量・高精度・高剛性・高効率などの特徴を有しており、世界の産業用ロボットメーカー、工作機械メーカー、一般産業機械メーカーより、高い評価を受けています。

#### 光造形システム分野・新事業

金型を使用せずに複雑な形の成型が可能な光造形装置、ユニークな熱輸送技術である蛇行細管型ヒートパイプを装着した高性能熱制御デバイス、また、金融機関等各種コールセンターなどでの利用が見込まれるデジタルロギングシステムは、いずれも今後の売上拡大が期待されます。

#### Precision Equipment Business

In this sector, our leading products are precision reduction gears and servo actuators that integrate servomotors and precision reduction gears. TEIJIN SEIKI's products are renowned for their characteristics such as small size, light weight, high precision, high stiffness and high level of efficiency, and are highly rated by manufacturers of industrial robots, machine tools and general industrial machinery world wide.

#### Optical Molding Systems Business and New Business

Future sales in this Business sector are expected to grow with such products as optical molding systems that can form complex shapes without the use of metal dies, high-performance heat control devices equipped with meandering capillary tube heat pipe that possess unique heat transfer technology, and digital logging systems that are expected to find applications such as call centers operated by firms such as financial institutions.

## 航空・油圧機器事業

### Aircraft and Oil Hydraulic Equipment

#### 航空機器分野

ボーイング社、セスナ社など、大手航空機メーカーへの操縦系統油圧アクチュエータを中心とした製品供給を行っており、日本企業の中で、航空機業界における国際プロジェクトを展開する代表的な企業として活躍しています。航空電源や流体ポンプおよびバルブ等の分野においても、米国の一流専門メーカーとの長期に亘る提携に基づき確実な事業成長を成し遂げています。

#### 油圧機器分野

油圧パワーシャベルにおいて足回りの要となる走行モーターを主製品としており、市場からの高い評価と信頼に基づき、高いマーケットシェアを維持しています。また、風力発電機用駆動装置の供給により、クリーンエネルギーとして今後成長が見込まれる風力発電市場へ参入し、省エネ・環境分野での事業拡大を進めていきます。

#### Aircraft Equipment Business

TEIJIN SEIKI supplies major aircraft manufacturers such as Boeing and Cessna with products centered on oil hydraulic actuators for flight control systems. Among Japanese firms, we play an active role as one of the leading aerospace companies working to develop international projects in the aircraft industry. Through long-time technical assistance arrangements maintained with leading American companies in the field of aerospace systems and products, such as electrical power generating systems, fluid pumping and valves, TEIJIN SEIKI has made a steady growth of business in such product lines in Japan.

#### Oil Hydraulic Equipment Business

With traveling motors required to turn the crawler pads of hydraulic power shovels as our primary product, TEIJIN SEIKI maintains a high market share based upon the high evaluation and solid trust it has earned from the market. And we just got started on supplying actuation unit for wind turbine. Thus, we are expanding our business, in the energy-saving and environment-friendly needs of market, to the wind turbine that is expected to grow as clean energy device.

## 繊維・産業機械事業

### Textile and Industrial Machinery

#### 繊維機械分野

紡糸機、巻取機、延伸機など一連の機械をシステムとして提供できる一貫生産設備を供給しており、この分野では常に世界のトップクラスの技術を誇っています。マーケットは、アジアをはじめ、オセアニア、欧米にまで広がっています。2002年4月、国内合繊機械メーカー3社の共同出資による新会社を設立いたしました。各社の合繊機械分野統合による事業基盤の強化を図っています。

#### 産業機械分野

これまで、様々な生産ラインにおける自動化・省力化・省人化に応える独創性の高い産業機械を供給してきました。中でも、自動充填包装機は食品業界において非常に高いシェアを有しており、洗剤、化学薬品産業などへも幅広く展開しています。

#### Textile Machinery Business

TEIJIN SEIKI supplies an integrated line-up of production equipment, which we can provide as a system of through production process such as spinning machines, winding machines and drawing machines. In this Business, TEIJIN SEIKI always boasts of the world top class technology. Beginning with Asia, we have expanded the market to which we supply textile machinery products to Oceania, Europe and North America. In April 2002, TEIJIN SEIKI, together with two other leading textile machinery manufacturing companies in Japan, has successfully established an on-site joint venture company, almost equally funded by these three companies and strategically and dedicatedly engaged in textile machinery manufacturing business. With this strategic unification or venture recently made, Textile Machinery sector of TEIJIN SEIKI has just moved ahead to strengthening its business base.

#### Industrial Machinery Business

Until now, TEIJIN SEIKI has supplied highly original industrial machinery that is designed to address automation, labor-savings, and mechanization for a variety of production lines as needed by the markets. We have been enjoying an extremely large share of the market in particular for automatic weighing and packaging machines for the food industry. Our company is also broadening its development of machinery for the detergent and the pharmaceutical industries as well.

# Segment Information (Consolidated Basis)

## セグメント情報（連結）

### 事業別売上高 Net Sales by Business

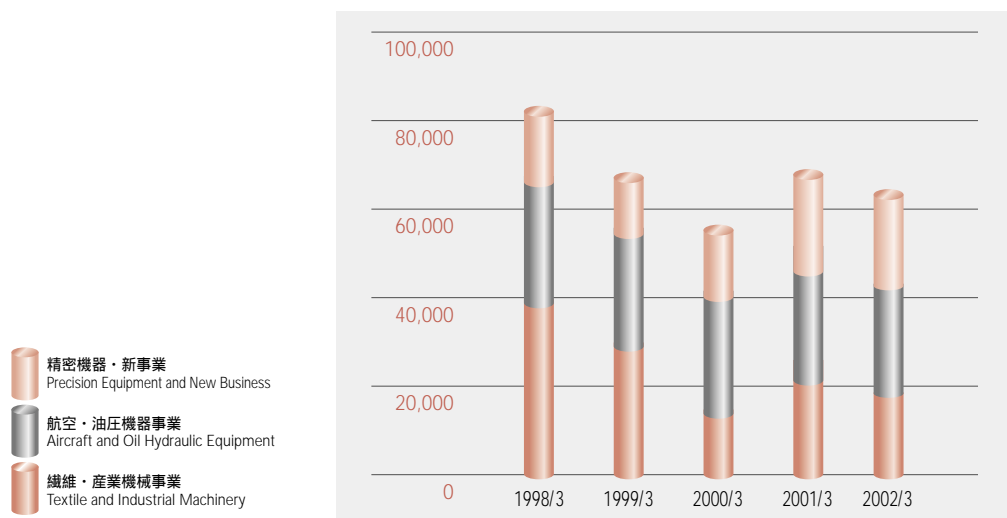

(単位：百万円 / ¥ Million)

		1998/3	1999/3	2000/3	2001/3	2002/3
精密機器・新事業	Precision Equipment and New Business	16,358	12,778	15,439	21,828	18,526
航空・油圧機器事業	Aircraft and Oil Hydraulic Equipment	26,697	24,920	25,596	24,667	25,395
繊維・産業機械事業	Textile and Industrial Machinery	38,528	29,008	13,672	21,369	18,245
合計	Total	81,584	66,707	54,707	67,864	62,168

### 事業別営業利益 Operating Income by Business

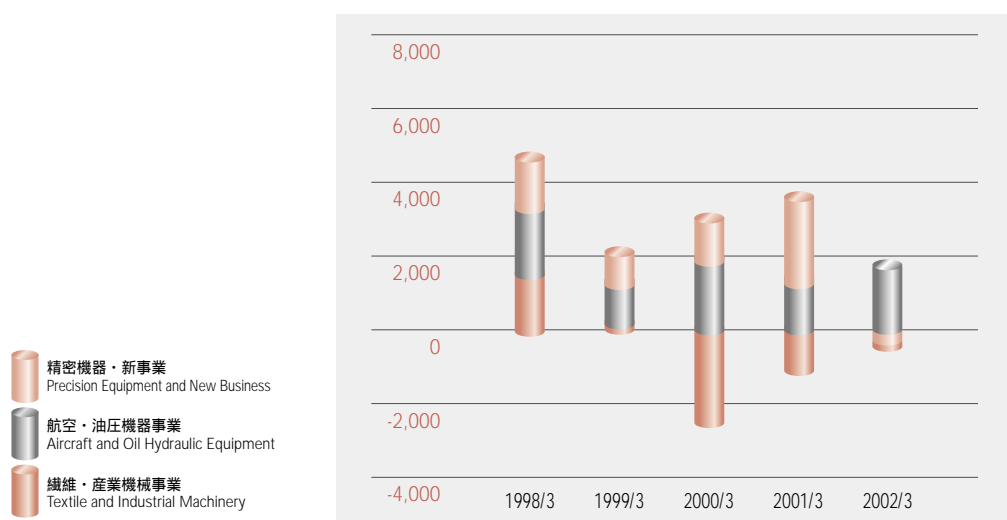

(単位：百万円 / ¥ Million)

		1998/3	1999/3	2000/3	2001/3	2002/3
精密機器・新事業	Precision Equipment and New Business	1,438	914	1,197	2,361	203
航空・油圧機器事業	Aircraft and Oil Hydraulic Equipment	1,775	1,130	1,857	1,247	1,979
繊維・産業機械事業	Textile and Industrial Machinery	1,509	87	2,546	1,105	69
合計	Total	4,720	2,134	504	2,508	1,705

## 所在地別売上高 Net Sales by Area

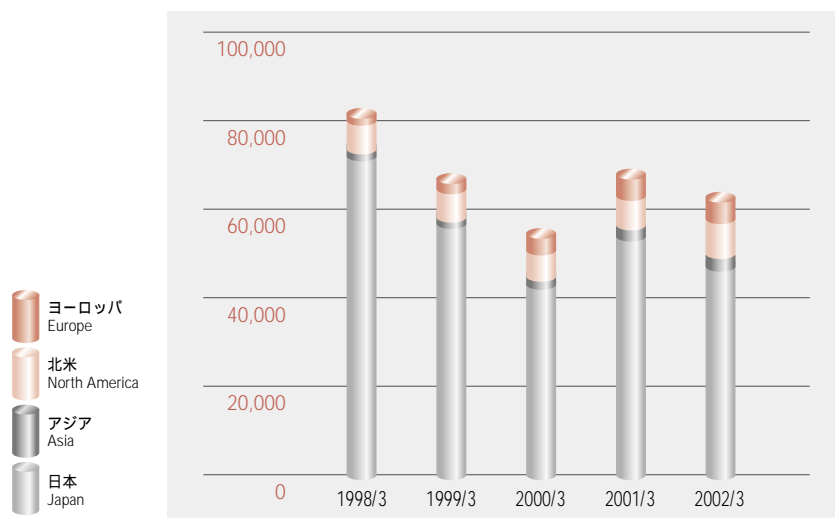

(単位：百万円 / ¥ Million)

		1998/3	1999/3	2000/3	2001/3	2002/3
日本	Japan	72,263	56,871	43,064	54,268	46,931
アジア	Asia	1,005	925	1,625	2,195	3,091
北米	North America	6,839	6,609	5,986	6,600	7,361
ヨーロッパ	Europe	1,475	2,301	4,031	4,800	4,783
合計	Total	81,584	66,707	54,707	67,864	62,168

## 海外売上高 Net Sales Overseas

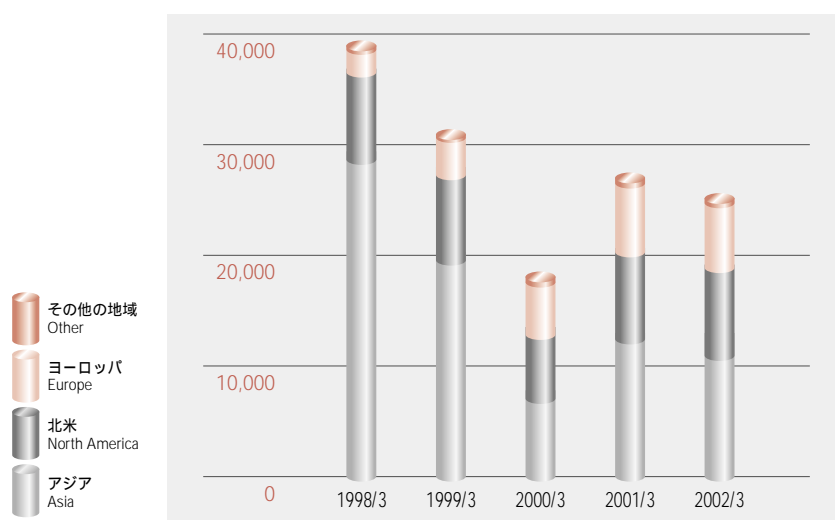

(単位：百万円 / ¥ Million)

		1998/3	1999/3	2000/3	2001/3	2002/3
アジア	Asia	28,674	19,512	6,991	12,810	11,276
北米	North America	7,856	7,676	5,813	7,677	7,870
ヨーロッパ	Europe	2,375	3,655	4,996	6,242	5,884
その他の地域	Other	118	109	239	261	183
合計	Total	39,024	30,953	18,040	26,992	25,214

# Main Consolidated Management Indices

## 主な経営指標（連結）

### 経営実績 Operating Results

売上高（百万円）  
Net Sales (¥ Million)

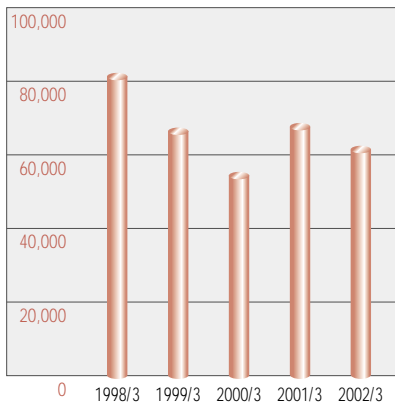

営業利益（百万円）  
Operating Income (¥ Million)

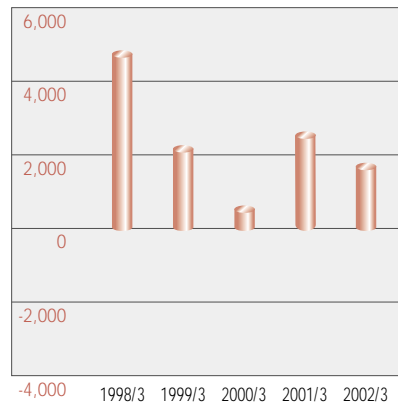

当期純利益（百万円）  
Net Income (¥ Million)

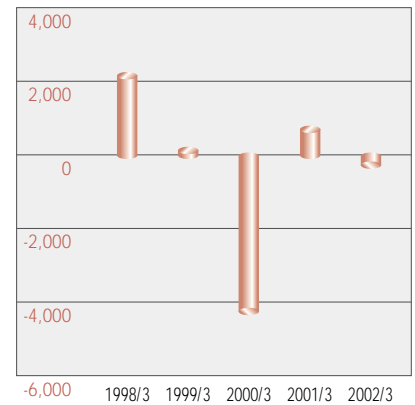

(単位：百万円 / ¥ Million)

		1998/3	1999/3	2000/3	2001/3	2002/3
売上高	Net Sales	81,584	66,707	54,707	67,864	62,168
売上総利益	Gross Profit	15,220	12,476	10,187	12,747	11,937
営業利益	Operating Income	4,720	2,134	504	2,508	1,705
経常利益	Ordinary Income	3,908	1,302	400	1,830	1,000
当期純利益	Net Income	2,172	96	4,252	686	306

### 収益性 Profitability

売上総利益率(%)  
Ratio of Gross Profit to Net Sales (%)

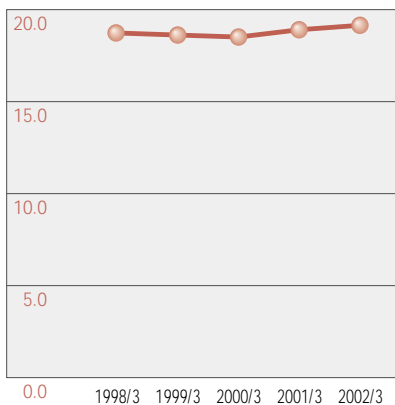

営業利益率(%)  
Ratio of Operating Income to Net Sales (%)

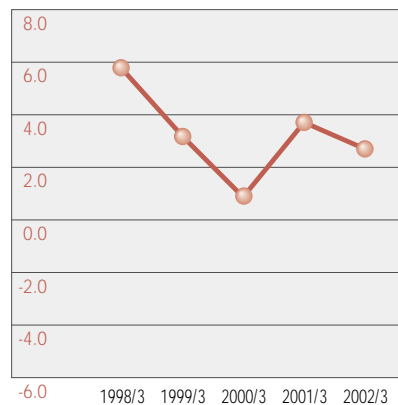

当期純利益率(%)  
Ratio of Net Income to Net Sales (%)

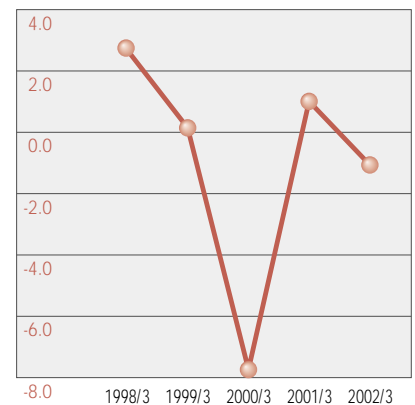

(単位：%)

		1998/3	1999/3	2000/3	2001/3	2002/3
売上総利益率	Ratio of Gross Profit to Net Sales	18.7	18.7	18.6	18.8	19.2
営業利益率	Ratio of Operating Income to Net Sales	5.8	3.2	0.9	3.7	2.7
経常利益率	Ratio of Ordinary Income to Net Sales	4.8	2.0	0.7	2.7	1.6
当期純利益率	Ratio of Net Income to Net Sales	2.7	0.1	7.8	1.0	0.5



## 財務状態 Financial Position

総資産(百万円)  
Total Assets (¥ Million)

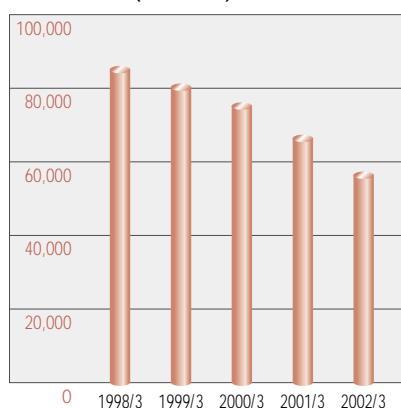

有利子負債(百万円)  
Interest-bearing Liabilities (¥ Million)

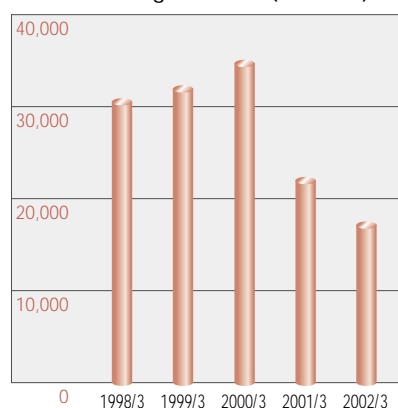

株主資本(百万円)  
Shareholders' Equity (¥ Million)

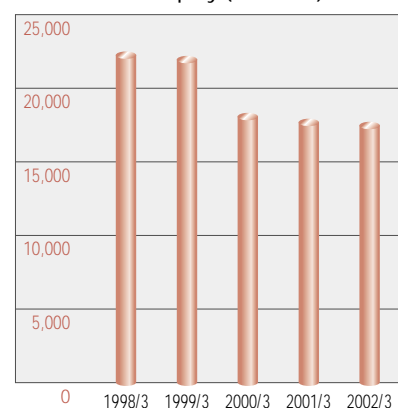

(単位: 百万円 / ¥ Million)

		1998/3	1999/3	2000/3	2001/3	2002/3
総資産	Total Assets	84,957	79,821	75,530	66,300	57,120
有利子負債	Interest-bearing Liabilities	30,546	31,938	34,771	22,009	17,146
株主資本	Shareholders' Equity	22,333	22,015	18,165	17,688	17,627

## 安定性 Stability

株主資本比率(%)  
Shareholders' Equity Ratio (%)

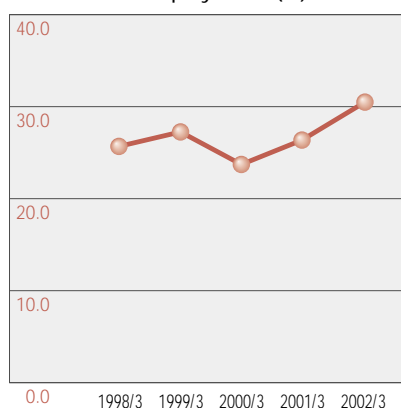

流動比率(%)  
Current Ratio (%)

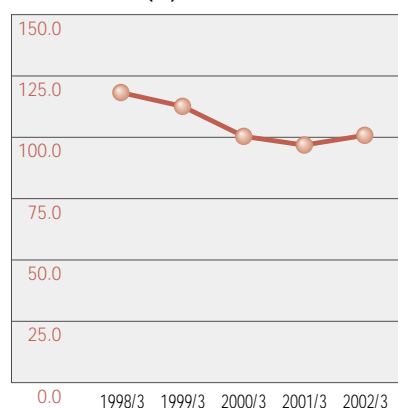

固定比率(%)  
Ratio of Fixed Assets to Shareholders' Equity (%)

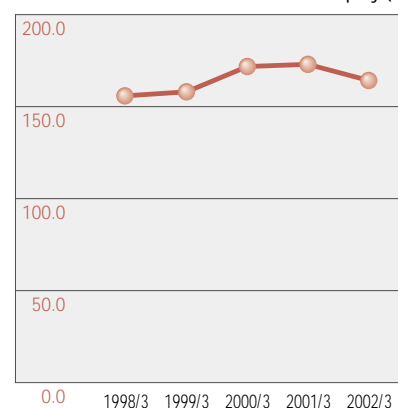

		1998/3	1999/3	2000/3	2001/3	2002/3
株主資本比率(%)	Shareholders' Equity Ratio (%)	26.3	27.6	24.1	26.7	30.9
流動比率(%)	Current Ratio (%)	118.0	112.8	100.2	96.7	101.3
固定比率(%)	Ratio of Fixed Assets to Shareholders' Equity (%)	156.6	158.0	171.8	173.0	164.8
手元流動性比率(月)	Cash Liquidity (Months)	1.7	1.5	2.5	0.3	0.3
インタレスト・カバレッジ(倍)	Interest Coverage (Times)	6.5	3.1	0.9	5.2	5.9

# Main Consolidated Management Indices

## 主な経営指標（連結）

### 効率性 Efficiency

総資本回転率(回)  
Total Assets Turnover (Times)

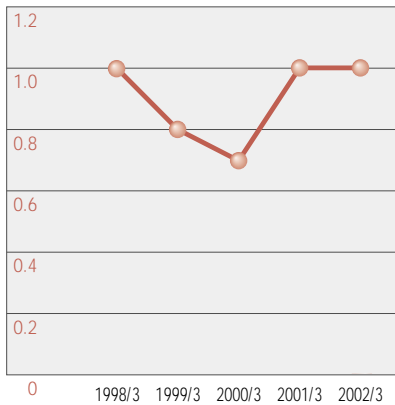

株主資本回転率(回)  
Shareholders' Equity Turnover (Times)

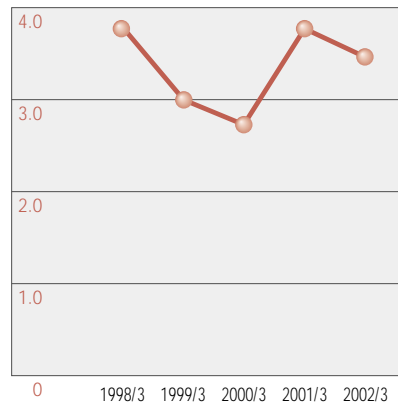

固定資産回転率(回)  
Fixed Assets Turnover (Times)

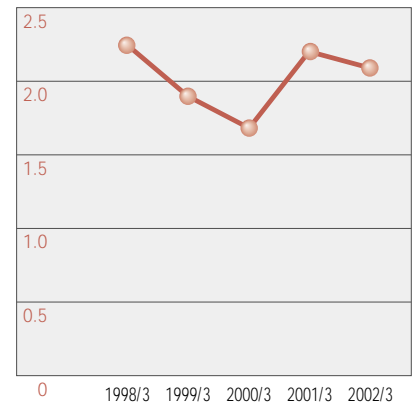

(単位：回 / Times)

		1998/3	1999/3	2000/3	2001/3	2002/3
総資本回転率	Total Assets Turnover	1.0	0.8	0.7	1.0	1.0
株主資本回転率	Shareholders' Equity Turnover	3.8	3.0	2.7	3.8	3.5
固定資産回転率	Fixed Assets Turnover	2.3	1.9	1.7	2.2	2.1

### 生産性 Productivity

従業員一人当たり売上高(百万円)  
Net Sales per Employee (¥ Million)

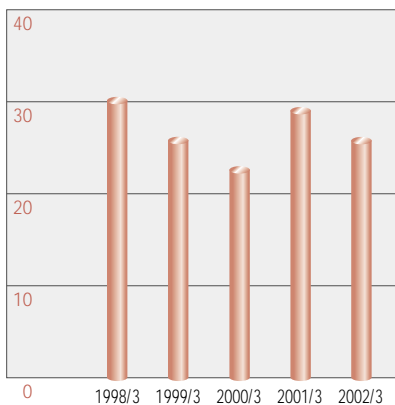

従業員一人当たり当期純利益(百万円)  
Net Income per Employee (¥ Million)

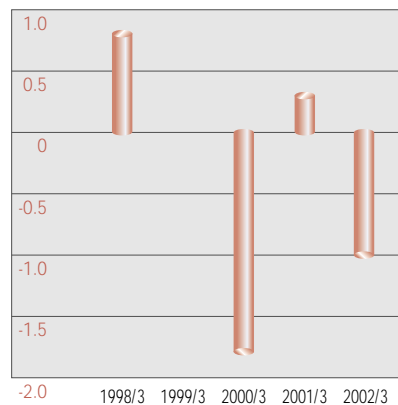

期末従業員数(連結)(人)  
Number of Employees (Consolidated) (persons)

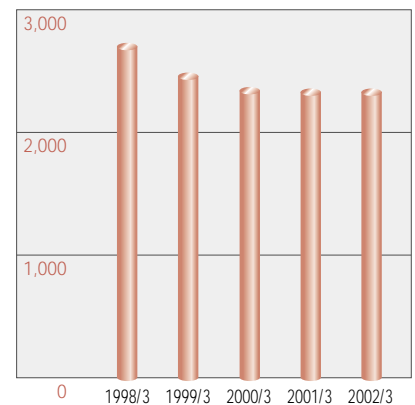

		1998/3	1999/3	2000/3	2001/3	2002/3
従業員一人当たり売上高(百万円)	Net Sales per Employee (¥ Million)	30.1	25.8	22.7	29.0	26.6
従業員一人当たり当期純利益(百万円)	Net Income per Employee (¥ Million)	0.8	0.0	1.8	0.3	0.1
期末従業員数(連結)(人)	Number of Employees (Consolidated) (Persons)	2,710	2,461	2,352	2,331	2,339
	(単体)					
	(Non-consolidated)	1,436	1,407	1,245	987	945

## キャッシュフロー Cash Flow

フリーキャッシュフロー(百万円)  
Free Cash Flow (¥ Million)

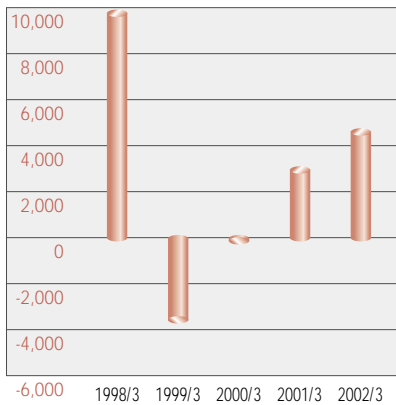

減価償却費(百万円)  
Depreciation Expense (¥ Million)

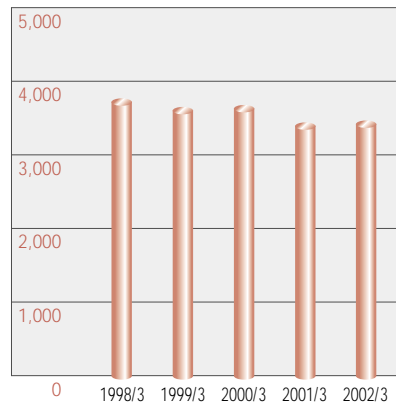

設備投資額(百万円)  
Capital Investment (¥ Million)

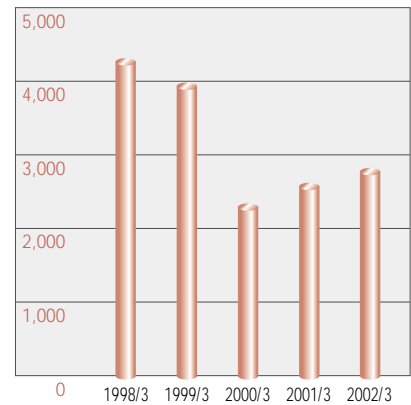

(単位: 百万円 / ¥ Million)

		1998/3	1999/3	2000/3	2001/3	2002/3
フリーキャッシュフロー	Free Cash Flow	9,781	3,670	85	3,306	4,655
減価償却費	Depreciation Expense	3,720	3,614	3,636	3,330	3,361
設備投資額	Capital Investment	4,261	3,931	2,282	2,538	2,865

注1) 減価償却費及び設備投資額には長期前払費用と繰延資産の償却額及び増加額がそれぞれ含まれている。

Note 1) Depreciation expenses and capital investment both include amortization of long-term prepaid expenses and increases in deferred charges.

注2) フリーキャッシュフロー = 「営業活動によるキャッシュフロー」 + 「投資活動によるキャッシュフロー」

Note 2) Free cash flow = cash flow provided by operating activities + cash flow used in investment activities

注3) 設備投資額は受入ベースの額。

Note 3) Capital investment is booked on a delivered basis.

## その他 Others

研究開発費(百万円)  
Research and Development Expense (¥ Million)

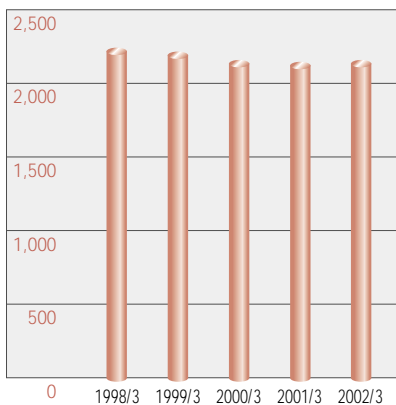

対売上高 R & D 比率(%)  
Ratio of R&D Expense to Net Sales (%)

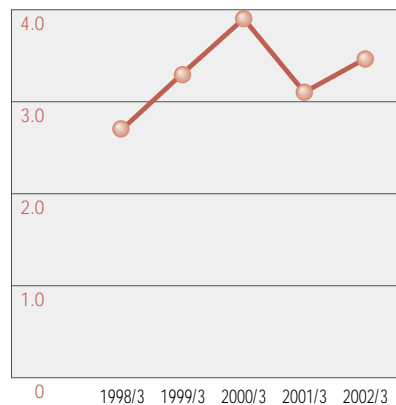

		1998/3	1999/3	2000/3	2001/3	2002/3
研究開発費(百万円)	Research and Development Expense (¥ Million)	2,217	2,188	2,133	2,117	2,159
対売上高 R & D 比率(%)	Ratio of R&D Expense to Net Sales (%)	2.7	3.3	3.9	3.1	3.5

## 主な投資指標（連結）

### 一株当り指標 Per Share Data

一株当り当期純利益(円)  
Net Income per Share (¥)

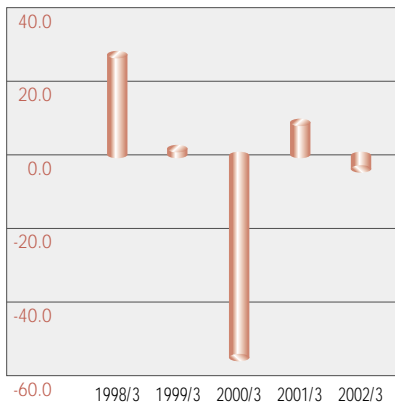

一株当り株主資本(円)  
Shareholders' Equity per Share (¥)

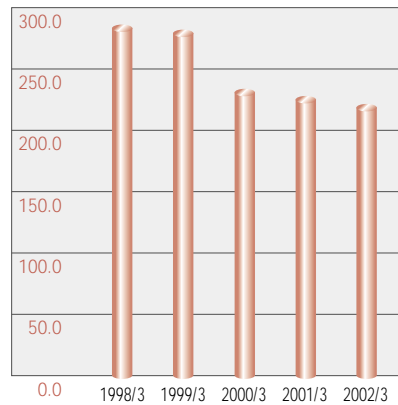

		1998/3	1999/3	2000/3	2001/3	2002/3
一株当り当期純利益(円)	Net Income per Share (¥)	27.64	1.22	54.10	8.74	3.90
一株当り株主資本(円)	Shareholders' Equity per Share (¥)	284.18	280.13	231.14	225.08	224.31

### その他 Others

株価株主資本倍率(倍)  
PBR (Times)

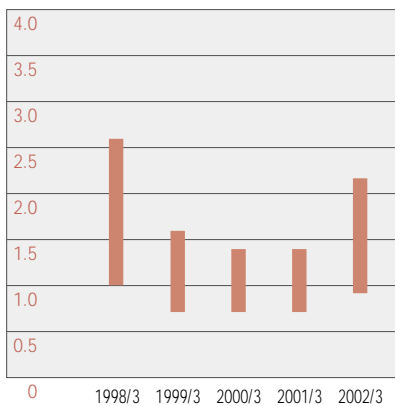

総資本当期純利益率(%)  
ROA (%)

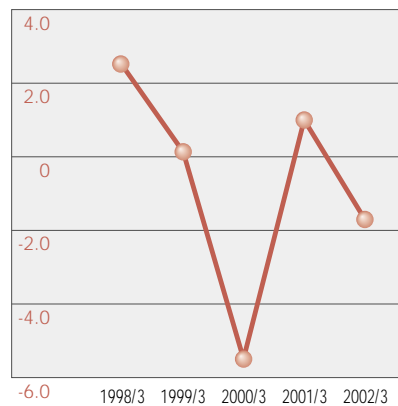

株主資本当期純利益率(%)  
ROE (%)

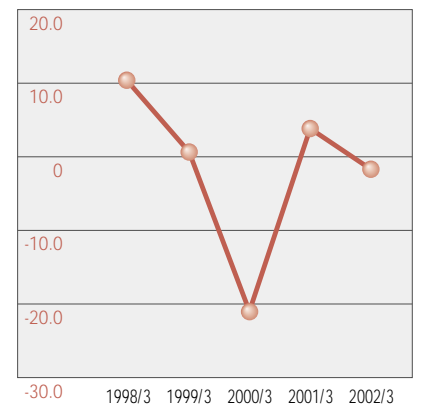

			1998/3	1999/3	2000/3	2001/3	2002/3
株価収益率(倍)	PER (Times)	最高値 High	26.9	368.9		36.7	
		最低値 Low	10.7	167.2		19.0	
株価株主資本倍率(倍)	PBR (Times)	最高値 High	2.6	1.6	1.4	1.4	2.2
		最低値 Low	1.0	0.7	0.7	0.7	0.9
総資本当期純利益率(%)	ROA (%)		2.6	0.1	5.5	1.0	0.5
株主資本当期純利益率(%)	ROE (%)		10.1	0.4	21.2	3.8	1.7

# Non-consolidated Supplemental Information

## 単体参考情報

		1998/3	1999/3	2000/3	2001/3	2002/3
売上高(百万円)	Net Sales (¥ Million)	63,645	53,208	40,407	36,340	34,629
売上総利益(百万円)	Gross Profit (¥ Million)	10,815	8,994	6,319	7,906	6,597
売上総利益率(%)	Ratio to Net Sales (%)	17.0	16.9	15.6	21.76	19.05
営業利益(百万円)	Operating Income (¥ Million)	3,490	1,829	131	3,096	2,171
売上高営業利益率(%)	Ratio to Net Sales (%)	5.5	3.4	0.3	8.5	6.3
経常利益(百万円)	Ordinary Income (¥ Million)	3,055	1,407	570	3,054	1,930
売上高経常利益率(%)	Ratio to Net Sales (%)	4.8	2.7	1.4	8.4	5.6
当期純利益(百万円)	Net Income (¥ Million)	1,362	344	3,005	2,384	1,763
売上高当期純利益率(%)	Ratio to Net Sales (%)	2.1	0.7	7.4	6.6	5.1
減価償却費(百万円)	Depreciation Expense (¥ Million)	3,128	3,095	3,001	2,679	2,527
設備投資額(百万円)	Capital Investment (¥ Million)	2,312	3,254	1,767	1,770	1,869
研究開発費(百万円)	Research and Development Expense (¥ Million)	2,030	1,841	1,756	1,241	1,137
総資産(百万円)	Total Assets (¥ Million)	69,990	67,588	65,573	53,122	45,548
株主資本(百万円)	Shareholders' Equity (¥ Million)	19,503	19,450	16,528	18,568	16,786
株主資本比率(%)	Shareholders' Equity Ratio (%)	27.9	28.8	25.2	35.0	36.9
流動比率(%)	Current Ratio (%)	115.8	110.3	89.6	84.7	101.5
固定比率(%)	Ratio of Fixed Assets to Shareholders' Equity (%)	165.6	166.8	196.3	172.6	155.8
総資本当期純利益率(%)	ROA (%)	2.0	0.5	4.5	4.0	3.6
株主資本当期純利益率(%)	ROE (%)	7.2	1.8	16.7	13.6	10.0
総資本回転率(回)	Total Assets Turnover (Times)	0.9	0.8	0.6	0.6	0.7
株主資本回転率(回)	Shareholders' Equity Turnover (Times)	3.3	2.7	2.2	2.1	2.0
固定資産回転率(回)	Fixed Assets Turnover (Times)	1.9	1.6	1.2	1.1	1.2
一株当たり配当金(円)	Cash Dividends per Share (¥)	5.50	4.00	3.00	3.00	3.00
配当性向(%)	Payout Ratio (%)	31.7	91.3		9.9	
発行済株式総数(株)	Number of Issued Shares (Shares)	78,590,321	78,590,321	78,590,321	78,590,321	78,590,321

注) 減価償却費及び設備投資額は有形固定資産に関する償却額及び増加額である。

Note) Depreciation expense and capital investment represent the depreciation on and increase in tangible fixed assets.

売上高(百万円)  
Net Sales (¥ Million)

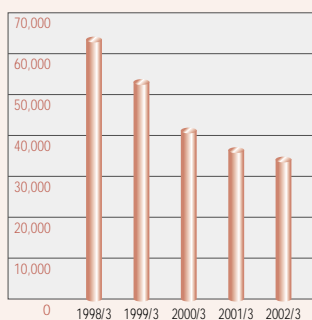

営業利益(百万円)  
Operating Income (¥ Million)

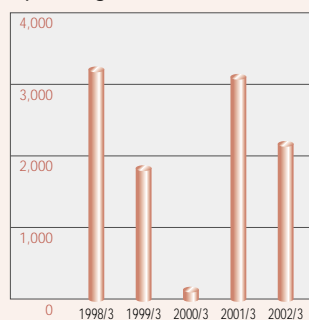

当期純利益(百万円)  
Net Income (¥ Million)

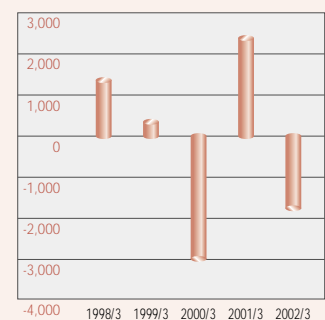

総資産(百万円)  
Total Assets (¥ Million)

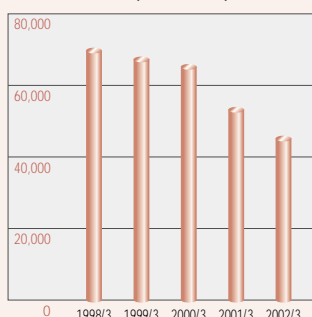

株主資本(百万円)  
Shareholders' Equity (¥ Million)

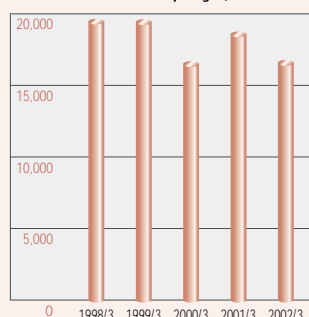

株主資本比率(%)  
Shareholders' Equity Ratio (%)

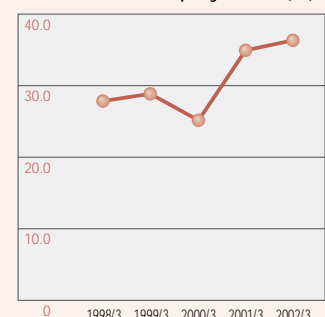

# Consolidated Balance Sheets

## 連結貸借対照表

(単位：百万円 / ¥ Million)

		1998/3	1999/3	2000/3	2001/3	2002/3
(資産の部)	Assets					
流動資産	Current assets					
現金及び預金	Cash and time deposits	3,597	5,089	3,609	1,601	1,356
受取手形及び売掛金	Trade notes and accounts receivable	21,652	17,819	14,961	21,274	14,577
有価証券	Marketable securities	3,175	3,848	449	—	—
たな卸資産	Inventories	14,809	15,963	14,248	11,712	10,157
繰延税金資産	Deferred income taxes	—	—	710	448	1,400
預け金	Deposits paid	4,900	—	7,952	201	13
その他	Other current assets	1,031	1,130	975	698	651
貸倒引当金	Allowance for doubtful receivables	204	181	199	312	161
流動資産合計	Total current assets	48,961	43,670	42,708	35,624	27,995
固定資産	Fixed assets					
有形固定資産	Property, plant and equipment					
建物及び構築物	Buildings and structures	21,133	21,841	21,863	22,048	21,975
減価償却費累計額	Accumulated depreciation	10,666	11,479	12,240	13,006	13,535
機械装置及び運搬器具	Machinery and equipment	32,320	33,235	32,345	32,859	33,232
減価償却費累計額	Accumulated depreciation	22,964	24,315	24,458	25,365	25,861
工具器具及び備品	Tools, furnitures and fixtures	6,458	6,809	6,666	7,065	7,579
減価償却費累計額	Accumulated depreciation	5,266	5,580	5,497	5,860	6,268
土地	Land	6,872	6,859	6,847	6,857	6,866
建設仮勘定	Construction in progress	40	294	291	93	90
有形固定資産合計	Total tangible fixed assets	27,927	27,663	25,818	24,691	24,078
無形固定資産	Intangible assets	811	665	668	1,033	1,005
投資その他の資産	Investments and other assets					
投資有価証券	Investments in securities	2,807	3,019	2,659	2,688	1,611
長期前払費用	Long-term prepaid expenses	303	259	347	227	350
繰延税金資産	Deferred income taxes	—	—	241	568	725
その他	Other investments and other assets	3,802	3,211	1,568	1,437	1,322
貸倒引当金	Allowance for doubtful receivables	669	36	97	54	87
投資その他の資産計	Total investments and other assets	6,243	6,454	4,719	4,867	3,922
固定資産合計	Total fixed assets	34,983	34,783	31,206	30,593	29,056
繰延資産	Deferred charges					
開業費	Business commencement expenses	193	148	104	83	68
繰延資産合計	Total deferred charges	193	148	104	83	68
為替換算調整勘定	Translation adjustments	818	1,219	1,510	—	—
資産合計	Total assets	84,957	79,821	75,530	66,300	57,120

(単位：百万円 / ¥ Million)

		1998/3	1999/3	2000/3	2001/3	2002/3
<b>(負債の部)</b>	<b>Liabilities</b>					
<b>流動負債</b>	<b>Current liabilities</b>					
支払手形及び買掛金	Trade notes and accounts payable	18,949	13,721	11,302	15,720	11,208
短期借入金	Short-term bank loans	14,867	17,328	14,907	12,938	11,147
一年内に償還する社債	Current portion of bonds	—	—	10,000	—	—
一年内に返済する長期借入金	Current portion of long-term loans	1,036	1,876	819	3,064	368
未払金	Account payable - other	2,582	2,470	3,193	2,009	1,964
未払法人税等	Income taxes payable	996	715	214	196	393
繰延税金負債	Deferred tax liabilities	—	—	—	89	14
賞与引当金	Accrued employees' bonuses	1,503	1,459	1,144	—	—
債務保証損失引当金	Reserve for loss of guarantee debts	—	—	—	26	26
その他	Other current liabilities	1,542	1,136	1,050	2,796	2,518
<b>流動負債合計</b>	<b>Total current liabilities</b>	<b>41,477</b>	<b>38,707</b>	<b>42,632</b>	<b>36,841</b>	<b>27,642</b>
<b>固定負債</b>	<b>Long-term liabilities</b>					
社債	Bonds	10,000	10,000	5,000	5,000	5,000
長期借入金	Long-term loans	4,642	2,734	4,044	1,006	630
退職給与引当金	Retirement allowances	4,405	4,504	3,895	—	—
退職給付引当金	Retirement allowances	—	—	—	4,038	4,339
役員退職慰労引当金	Reserve for directors' retirement account	—	—	—	328	339
その他	Other long-term liabilities	609	534	505	541	578
<b>固定負債合計</b>	<b>Total long-term liabilities</b>	<b>19,657</b>	<b>17,772</b>	<b>13,445</b>	<b>11,009</b>	<b>10,888</b>
少数株主持分	Minority interests	1,489	—	—	—	—
<b>負債合計</b>	<b>Total liabilities</b>	<b>62,624</b>	<b>56,480</b>	<b>56,078</b>	<b>47,850</b>	<b>38,530</b>
<b>(少数株主持分)</b>	<b>Minority interests</b>					
少数株主持分	Minority interests	—	1,325	1,287	761	962
<b>(資本の部)</b>	<b>Shareholders' equity</b>					
資本金	Capital stock	6,623	6,623	6,623	6,623	6,623
資本準備金	Additional paid-in capital	6,287	6,287	6,287	6,287	6,287
連結剰余金	Retained earnings	9,423	9,105	5,255	5,694	5,055
その他有価証券評価差額金	Net unrealized gains on securities	—	—	—	107	126
為替換算調整勘定	Translation adjustments	—	—	—	808	463
自己株式	Treasury stock, at cost	0	0	0	0	1
<b>資本合計</b>	<b>Total shareholders' equity</b>	<b>22,333</b>	<b>22,015</b>	<b>18,165</b>	<b>17,688</b>	<b>17,627</b>
<b>負債、少数株主持分及び資本合計</b>	<b>Total liabilities, minority interests and shareholders' equity</b>	<b>84,957</b>	<b>79,821</b>	<b>75,530</b>	<b>66,300</b>	<b>57,120</b>

# Consolidated Statements of Income

## 連結損益計算書

(単位：百万円 / ¥ Million)

		1998/3	1999/3	2000/3	2001/3	2002/3
売上高	Net sales	81,584	66,707	54,707	67,864	62,168
売上原価	Cost of sales	66,363	54,231	44,520	55,117	50,230
売上総利益	Gross profit	15,220	12,476	10,187	12,747	11,937
販売費及び一般管理費	Selling, general and administrative expenses	10,500	10,342	9,683	10,238	10,232
営業利益	Operating income	4,720	2,134	504	2,508	1,705
営業外収益	Non-operating income					
受取利息	Interest income	91	63	27	21	12
受取配当金	Dividend income	31	38	23	28	13
有価証券売却益	Gain on sales of securities	0	—	0	—	—
持分法による投資利益	Equity in earnings of an affiliate	—	111	83	25	48
その他	Other	203	218	200	121	160
営業外費用	Non-operating expenses					
支払利息	Interest expense	742	723	603	490	294
為替差損	Foreign exchange loss	236	332	154	—	44
その他	Other	160	208	481	384	602
経常利益	Ordinary income	3,908	1,302	400	1,830	1,000
特別利益	Extraordinary gains					
固定資産売却益	Gain on sales of fixed assets	343	2	2	192	47
投資有価証券売却益	Gain on sales of investment securities	—	—	—	110	31
その他	Other	5	17	63	28	111
特別損失	Extraordinary losses					
固定資産処分損	Losses on sales of fixed assets	111	80	145	191	103
投資有価証券評価損	Write-down of investment securities	595	69	154	3	1,565
ゴルフ会員権評価損	Write-down of golf membership rights	—	—	—	153	102
退職給付費用	Special contribution to a pension fund	—	—	—	494	494
非連結子会社整理損	Loss on disposal of unconsolidated subsidiaries	370	356	—	—	—
構造改善費用	Restructuring cost	—	—	3,812	—	—
その他	Other	—	—	30	62	64
税金等調整前当期純利益	Income before income taxes	3,180	817	4,477	1,255	1,139
法人税等：	Income taxes：					
法人税、住民税及び事業税	Current	1,111	881	379	378	527
法人税等調整額	Deferred	—	—	562	236	1,445
少数株主持分への振替利益(減算)	Minority interests in net income of consolidated subsidiaries	—	—	—	—	85
少数株主持分への振替損失(加算)	Minority interests in net losses of consolidated subsidiaries	53	160	43	45	—
持分法による投資利益	Equity in earnings of an affiliate	49	—	—	—	—
当期純利益	Net income	2,172	96	4,252	686	306



# Consolidated Statements of Cash Flows

## 連結キャッシュ・フロー計算書

(単位：百万円 / ¥ Million)

		2000/3	2001/3	2002/3
<b>I 営業活動によるキャッシュ・フロー</b>	<b>Operating activities:</b>			
税金等調整前当期純利益	Income before income taxes	4,477	1,255	1,139
減価償却費	Depreciation and amortization	3,636	3,330	3,361
連結調整勘定償却	Amortization of cost in excess of net book values of consolidated subsidiaries	2	20	57
貸倒引当金の増加額又は減少額( )	Provision for allowance for doubtful receivables	78	67	121
賞与引当金の減少額	Decrease in accrued employees' bonuses	354	—	—
退職給与引当金の減少額	Decrease in retirement allowances	595	3,472	—
退職給付引当金の増加額	Provision for retirement benefits of employees	—	4,038	284
役員退職慰労引当金の増加額又は減少額( )	Provision for (reversal of) retirement	—	95	11
受取利息及び受取配当金	Interest and dividend income	50	50	37
支払利息	Interest expense	603	490	294
為替損益	Foreign exchange gain or loss	30	62	50
持分法による投資利益	Equity in earnings of an affiliate	83	25	48
固定資産売却益	Gain on sales of fixed assets	—	192	47
固定資産除却損	Loss on disposal of fixed assets	404	191	103
投資有価証券売却益	Gain on sales of investment securities	—	110	31
投資有価証券評価損	Losses from valuation on investment marketable securities	154	4	1,565
ゴルフ会員権評価損	Write-down of golf membership rights	—	106	64
売上債権の減少額又は増加額( )	Decrease or increase in notes and accounts receivable	2,852	5,451	6,710
たな卸資産の減少額	Decrease in inventories	1,513	2,910	1,794
その他資産の減少額又は増加額( )	Decrease or increase in other assets	136	112	44
仕入債務の減少額 又は増加額	Decrease or increase in notes and accounts payable	2,238	3,971	4,654
未払消費税等の減少額( )又は増加額	Decrease or increase in consumption taxes payable	432	71	27
その他負債の減少額( )又は増加額	Decrease or increase in other liabilities	1,403	1,064	274
役員賞与の支払額	Bonuses to directors	22	11	33
小計	Subtotal	3,091	5,791	7,880
利息及び配当金の受取額	Interest and dividends received	49	112	47
利息の支払額	Interest paid	590	540	318
法人税等の支払額	Income taxes paid	881	371	336
営業活動によるキャッシュ・フロー	Net cash and cash equivalents provided by operating activities	1,669	4,992	7,273
<b>II 投資活動によるキャッシュ・フロー</b>	<b>Investing activities:</b>			
定期預金の解約による収入	Proceeds from cancellation of fixed deposit	—	50	—
有価証券の売却による収入	Proceeds from sales of marketable securities	41	—	—
有形固定資産の取得による支出	Purchases of property, plant and equipment	3,304	1,863	2,630
有形固定資産の売却による収入	Proceeds from sales of property, plant and equipment	44	234	389
投資有価証券の取得による支出	Purchases of investments in securities	34	16	0
投資有価証券の売却による収入	Proceeds from sales of investments in securities	26	322	49
非適格年金積立金解約による収入	Proceeds from cancellation of pension fund	1,052	—	—
関係会社株式の取得による支出	Purchases of investments in securities of subsidiaries and affiliates	—	—	61
子会社株式取得による支出	Increase in investments in subsidiaries	88	314	—
貸付金の実行による支出	Payment of short-term loans	46	1	6
貸付金の回収による収入	Proceeds from repayment of short-term loans	—	44	0
その他投資活動による収入	Proceeds from other investing activities	717	64	69
その他投資活動による支出	Expenses for other investing activities	164	204	428
投資活動によるキャッシュ・フロー	Net cash and cash equivalents used in investing activities	1,755	1,685	2,618
<b>III 財務活動によるキャッシュ・フロー</b>	<b>Financing activities:</b>			
短期借入金の純減少額	Decrease in short-term bank loans	13	2,096	1,918
長期借入れによる収入	Proceeds from long-term loans	286	61	—
長期借入金の返済による支出	Repayment of long-term loans	2,263	857	3,064
社債の発行による収入	Proceeds from corporate bond issue	5,000	—	—
社債の償還による支出	Repayments of debentures	—	10,000	—
少数株主からの払込みによる収入	Proceeds from payment of minority	—	60	16
配当金の支払額	Cash dividends paid	158	235	235
少数株主への配当金の支払額	Cash dividends paid of subsidiaries for minority	—	—	2
財務活動によるキャッシュ・フロー	Net cash and cash equivalents provided by financing activities	2,850	13,068	5,205
IV 現金及び現金同等物に係る換算差額	Effect of exchange rate changes on cash and cash equivalents	119	52	117
V 現金及び現金同等物の増加額又は減少額( )	Increase or decrease in cash and cash equivalents	2,645	9,708	433
VI 現金及び現金同等物の期首残高	Cash and cash equivalents at beginning of year	8,508	11,512	1,803
新規連結による現金及び現金同等物増加額	Increase in cash and cash equivalents resulting from initial consolidation of subsidiaries	357	—	—
VII 現金及び現金同等物の期末残高	Cash and cash equivalents at end of year	11,512	1,803	1,370

## 株式情報

### 株価 Stock Price

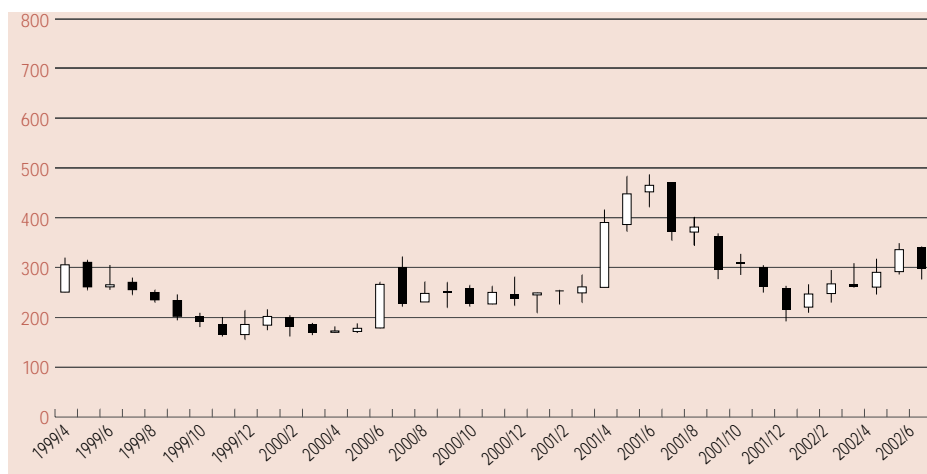

注) 1999年8月20日に当社株式が東証の指定銘柄となっておりますので、1999年9月までは大証の数字で、同年10月以降は東証の数字でグラフを作成しております。

Note) Because our stock became a specified issue on the Tokyo Stock Exchange on August 20, 1999, the above graph has been prepared using figures from the Osaka Securities Exchange until September 1999 and those of the Tokyo Stock Exchange thereafter.

#### 大証

#### Osaka Securities Exchange

	始値 / Open	高値 / High	安値 / Low	終値 / Close
1999/ 4	250	320	250	306
1999/ 5	311	315	255	261
1999/ 6	261	305	255	266
1999/ 7	271	280	246	255
1999/ 8	250	255	230	235
1999/ 9	234	246	194	202
1999/10	207	210	179	196
1999/11	195	195	157	165
1999/12	175	210	150	172
2000/ 1	187	213	173	201
2000/ 2	201	205	155	176
2000/ 3	175	190	163	168
2000/ 4	169	181	163	172
2000/ 5	173	184	167	177
2000/ 6	177	270	177	270
2000/ 7	295	319	220	225
2000/ 8	250	280	231	249
2000/ 9	248	271	220	250
2000/10	258	264	221	231
2000/11	231	264	226	254
2000/12	250	280	225	240
2001/ 1	245	254	205	250
2001/ 2	250	256	231	252
2001/ 3	257	283	230	265
2001/ 4	268	419	268	388
2001/ 5	384	480	368	445
2001/ 6	434	480	419	453
2001/ 7	468	468	358	370
2001/ 8	374	395	350	370
2001/ 9	370	370	283	287
2001/10	320	320	304	304
2001/11	304	304	288	291
2001/12	291	291	224	224
2002/ 1	234	263	220	263
2002/ 2	263	281	240	270
2002/ 3	290	308	285	295
2002/ 4	252	294	247	294
2002/ 5	292	305	287	305
2002/ 6	338	338	328	328

#### 東証

#### Tokyo Stock Exchange

	始値 / Open	高値 / High	安値 / Low	終値 / Close
1999/ 4	251	312	251	305
1999/ 5	301	314	251	260
1999/ 6	265	310	250	266
1999/ 7	266	275	240	250
1999/ 8	255	262	229	240
1999/ 9	232	242	195	202
1999/10	202	208	179	190
1999/11	185	200	160	164
1999/12	164	213	154	185
2000/ 1	183	215	173	201
2000/ 2	201	203	160	180
2000/ 3	185	188	163	168
2000/ 4	168	181	167	171
2000/ 5	170	188	166	177
2000/ 6	177	270	177	266
2000/ 7	300	321	221	226
2000/ 8	231	272	231	248
2000/ 9	253	271	220	250
2000/10	258	265	222	227
2000/11	227	262	227	250
2000/12	246	282	224	237
2001/ 1	245	250	209	249
2001/ 2	253	254	226	253
2001/ 3	249	285	230	261
2001/ 4	260	415	260	389
2001/ 5	385	482	370	446
2001/ 6	450	485	420	463
2001/ 7	468	468	353	370
2001/ 8	370	400	344	380
2001/ 9	365	369	277	298
2001/10	310	328	285	307
2001/11	302	305	250	261
2001/12	260	264	192	216
2002/ 1	220	267	210	248
2002/ 2	248	295	230	268
2002/ 3	268	309	260	262
2002/ 4	260	318	246	290
2002/ 5	292	348	286	336
2002/ 6	340	341	275	297

# Subsidiaries and Affiliates

## 子会社・関連会社

### 連結子会社 Consolidated Subsidiaries

(2002年6月30日現在 As of June 30, 2002)

社名 Name	設立又は系列化 Year of Incorporation or Acquisition	資本金 Paid-in Capital	持株比率 Equity Ownership	事業区分 Business Segment
大亜真空株式会社 Diavac Limited	1971	135百万円 / ¥135Million	100.0%	精密機器・新事業  Precision Equipment and New Business
ティーエス ヒートロニクス株式会社 TS Heatronics Co., Ltd.	1999	200百万円 / ¥200Million	95.0%	
ログイット株式会社 LogIT Corporation	1999	100百万円 / ¥100Million	96.5%	
シーメット株式会社 CMET INC.	2000	400百万円 / ¥400Million	92.5%	
真空サービス株式会社 Vacuum-tech Service Co., Ltd.	1980	10百万円 / ¥10Million	100.0%	
TEIJIN SEIKI BOSTON, INC.	1991	7百万 U.S.ドル / US\$7Million	100.0%	
TEIJIN SEIKI EUROPE GmbH	1992	100千D.M. / D.M.100Thousand	100.0%	
TEIJIN SEIKI ADVANCED TECHNOLOGIES, INC.	1999	500千U.S.ドル / US\$500Thousand	100.0%	
株式会社スイコー Suikoh Co., Ltd.	1991	15百万円 / ¥15Million	100.0%	航空・油圧 機器事業
TEIJIN SEIKI AMERICA, INC.	1976	1百万 U.S.ドル / US\$1Million	100.0%	
上海帝人製機有限公司 Shanghai Teijin Seiki Co., Ltd.	1996	14.5百万 U.S.ドル / US\$14.5Million	51.0%	
TEIJIN SEIKI USA, INC.	1999	1千U.S.ドル / US\$1Thousand	100.0%	Aircraft and Oil Hydraulic Equipment
帝人製機テキスタイルマシナリー株式会社 Teijin Seiki Textile Machinery Co., Ltd.	2000	490百万円 / ¥490Million	100.0%	繊維・産業 機械事業  Textile and Industrial Machinery
東洋自動機株式会社 Toyo Jidoki Co., Ltd.	1966	50百万円 / ¥50Million	100.0%	
帝人製機プレシジョン株式会社 Teijin Seiki Precision Co., Ltd.	1995	50百万円 / ¥50Million	100.0%	
株式会社ティ・エス・メカテック T-S-MECHATECH Co., Ltd.	1978	10百万円 / ¥10Million	100.0%	
愛新機工株式会社 Aishin Kikoo Co., Ltd.	1978	10百万円 / ¥10Million	100.0%	
株式会社麻里布エンジニアリング Marifu Engineering Co., Ltd.	1995	10百万円 / ¥10Million	100.0%	
P. T. PAMINDO TIGA T	1975	1,448百万ルピア / RP1,448Million	50.9%	
上海帝人製機紡機有限公司 Shanghai Teijin Seiki Textile Machinery Co., Ltd.	2000	2.6百万 U.S.ドル / US\$2.6Million	80.0%	

連結子会社：20社（国内12社・海外8社）

### 持分法適用関連会社 Affiliate (accounted for by equity method)

エス・ティ・エス株式会社 STS Corporation	1982	400百万円 / ¥400Million	50.0%
ティエムティマシナリー株式会社 TMT MACHINERY, INC.	2002	90百万円 / ¥90Million	33.0%

持分法適用関連会社：2社（国内）

# 会社情報

2002年6月30日現在

# Corporate Data

As of June 30, 2002

商号	帝人製機株式会社
設立	昭和19年8月18日
本社	東京都港区西新橋三丁目3番1号
資本金	6,623,132,460円
従業員数	945名(単体) 2,339名(連結) (2002年3月31日現在)

Company Name	TEIJIN SEIKI CO., LTD.
Establishment	August 18, 1944
Head Office	3-3-1, Nishi-Shimbashi, Minato-ku, Tokyo
Capital Stock	¥6,623,132,460
Employees	945 (Non-consolidated) 2,339 (Consolidated) (As of March 31, 2002)

## 取締役会

代表取締役社長	興津 誠
代表取締役専務取締役	山田 義親
常務取締役	山中 盛男
取締役	中川 勝正
取締役	松本 和幸
社外取締役(帝人(株)代表取締役専務取締役)	長島 徳明

## Board of Directors

President	Makoto Okitsu
Senior Managing Director, Director on Board	Yoshichika Yamada
Managing Director, Director on Board	Morio Yamanaka
Director on Board	Katsumasa Nakagawa
Director on Board	Kazuyuki Matsumoto
Director on Board (Senior Managing Director, TEIJIN LIMITED)	Noriaki Nagashima

## 監査役会

常勤監査役	松田 孝介
監査役	星田 康
監査役	石丸 哲也

## Board of Statutory Auditors

Statutory Auditor	Kosuke Matsuda
External Statutory Auditor	Yasushi Hoshida
External Statutory Auditor	Tetsuya Ishimaru

## 業務執行体制

最高経営責任者(CEO)	興津 誠
専務執行役員(技術開発室長)	山田 義親
常務執行役員(企画管理室長)	山中 盛男
常務執行役員(航空・油機カンパニー社長(航空機担当))	田中 均
執行役員(航空・油機カンパニー副社長(油機担当))	中川 勝正
執行役員(航空・油機カンパニー社長補佐 兼 岐阜事業所横浜開発センター所長)	小林 盛男
執行役員(航空・油機カンパニー社長補佐 兼 エス・ティ・エス(株)代表取締役社長)	岡本 正巳
執行役員(ログイット(株)代表取締役社長)	立古 史朗
執行役員(帝人製機プレジジョン(株)代表取締役社長)	新井 信敏
執行役員(東洋自動機(株)代表取締役社長)	佐々木 慧
執行役員(ティーエス ヒートロニクス(株)代表取締役社長)	松本 和幸
執行役員(シーメット(株)代表取締役社長)	佐原 健
執行役員(精機カンパニー社長 兼 精機計画部長)	児山 立平
執行役員(技術開発室長補佐 兼 生産技術部長)	中村 秀一

## Corporate Officers

Chief Executive Officer	Makoto Okitsu
Senior Executive Officer General Manager, Office of Technical Development	Yoshichika Yamada
Executive Officer General Manager, Office of Corporate Management	Morio Yamanaka
Executive Officer President, Aircraft & Oil Hydraulic Equipment Company	Hitoshi Tanaka
Corporate Officer President, Oil Hydraulic Equipment Company	Katsumasa Nakagawa
Corporate Officer VP, Aircraft Equipment Company	Morio Kobayashi
Corporate Officer President, STS Corporation	Masami Okamoto
Corporate Officer President, LogIT Corporation	Shiro Ryugo
Corporate Officer President, Teijin Seiki Precision Co., Ltd.	Nobutoshi Arai
Corporate Officer President, Toyo Jidoki Co., Ltd.	Akira Sasaki
Corporate Officer President, TS Heatronics Co., Ltd.	Kazuyuki Matsumoto
Corporate Officer President, CMET INC.	Ken Sahara
Corporate Officer President, Precision Equipment Company	Ryuhei Koyama
Corporate Officer Deputy General Manager, Office of Technical Development	Shuichi Nakamura

国内事業所	7拠点
子会社・関係会社	22社
株式名義書換代理人	UFJ 信託銀行株式会社
会計監査人	朝日監査法人
取引所	東京証券取引所市場第一部 大阪証券取引所市場第一部 名古屋証券取引所市場第一部

Offices	7
Subsidiaries and Affiliates	22
Stock Transfer Agent	UFJ Trust Bank Limited
Independent Public Accountants	Asahi & Co
Stock Exchange Listings	First Section, Tokyo Stock Exchange First Section, Osaka Securities Exchange First Section, Nagoya Stock Exchange

## 帝人製機株式会社

本社  
〒105-8628  
東京都港区西新橋三丁目3番1号 西新橋TSビル  
Tel (03)3578-7450  
Fax (03)3578-7470  
ホームページ <http://www.teijinseiki.co.jp/>  
再生紙を使用しています。

## TEIJIN SEIKI CO.,LTD.

Head Office  
Nishi-Shimbashi TS Building, 3-3-1, Nishi-Shimbashi,  
Minato-ku, Tokyo 105-8628  
Phone 81-3-3578-7450  
Fax 81-3-3578-7470  
URL <http://www.teijinseiki.co.jp/>  
This document is printed on recycled paper.

